

# Scientific Aviation Association Aachen

Accelerating Hybrid Powertrain Testing and Certification



**speedgoat**  
real-time simulation and testing



**The Scientific Aviation Association (FVA) in Aachen, Germany, is accelerating hybrid powertrain testing for the new FVA30 aircraft with a Speedgoat target computer. It acts as the electrical system's main control unit and forms an integrated part of the iron bird.**

The FVA is an organization dedicated to the research and development of aircraft components and complete aircrafts. This group of aviation students is well established in the aviation community. They exist for over 100 years and have been responsible for many great innovations throughout those years.

Their latest innovation is the FVA30 hybrid-electric aircraft. It combines many ground-breaking technologies, such as new battery management and cooling technologies, hybrid power

generation ideas, and important aircraft control inventions. While the airframe is comparable to one of modern sailplanes, the two electric motors on top of the V-Tail indicate that this aircraft can do more than just gliding.

The FVA30 prototype provides the FVA an ideal platform to test and certify aircraft components for a hybrid-electric system with motors mounted at the end of the V-tail. With the certification of this innovation being one of the main challenges, the FVA30 required a setup allowing extensive verification and testing.

### The Challenge

To build, test, and certify the hybrid-electric aircraft, FVA needed an iron bird to test individual components, complete control strategies, and show compliance with the respective aviation authority requirements.

Before applying the Speedgoat and MathWorks workflow, FVA lacked a seamless modeling, simulation, and testing platform, therefore having to resort to a multitude of non-connected software and hardware components.



Shortly after starting with the powertrain design of the FVA30, engineers realized that using multiple isolated tools to design, test, and certify the hybrid-electric aircraft was insufficient: It wasn't possible to rapidly try out and test new ideas and concepts.

To overcome this hurdle, the team decided to design all control algorithms in Simulink® and leverage a Speedgoat target computer as a prototype for the final controller.

Speedgoat target computers do not only provide seamless I/O integration for data acquisition and signal generation, but they are instrumental to rapidly iterate new control concepts from Simulink and to easily inject faults to prove a correct error handling.

Moreover, all testing can be automated, such as through scripts and automated documentation, enabling both encompassing and efficient compliance testing to meet certification requirements.

### Real-Time Controls

For controls, FVA students are leveraging a Baseline real-time target machine performing many control tasks: Analog and digital I/O lines are used to read commands such as throttle, elevator configuration, and

“The Speedgoat real-time target machine enables us to rapidly iterate and test. It's ideal to achieve highest test coverage for our hybrid-electric aircraft.”



Marcel Grigo, Powertrain Department at FV Aachen

motor-control related functions from an external test person acting as the pilot.

Complex Simulink-based control algorithms are then computing torque values in real-time, driving inverters and sending commands to an off-the-shelf battery management system (BMS) over CAN.

The BMS observes the State of Charge (SoC) and the battery's temperature, for example, to ensure that batteries are in a safe state before, during, and after the flight. This information is regularly sent to the main controller, which can provide the pilot with the necessary information and warnings.

Having a fully-featured controller with seamless Simulink integration allows the team to rapidly diagnose the system, identify remaining weak points, and confirm proper operation through automated compliance testing.

### Certification

The Speedgoat platform with seamless Simulink integration provides the FVA team an efficient toolchain to meet compliance requirements for standards such as CS-22 / CS-23 for the aircraft or DO-160 and DO-311 for the battery configuration.

It also provides a path enabling further tests such as, for example, the integration of an autopilot.

## Diagram of the Iron Bird Test Bench

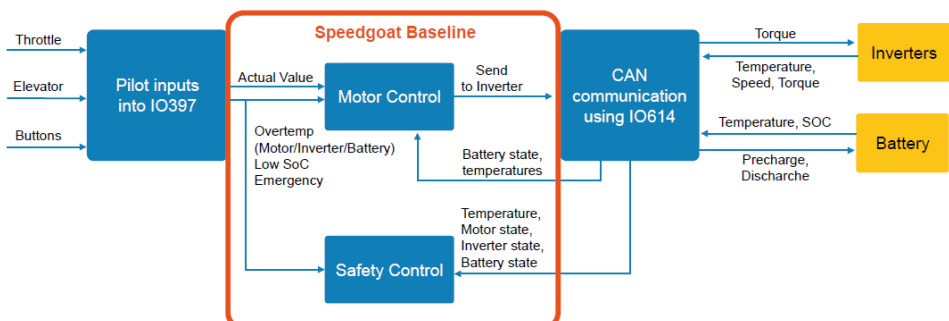

**Utilized Speedgoat products:**

- » Baseline real-time target machine
- » IO397 Programmable FPGA I/O module
- » IO614 CAN I/O Module

**Utilized MathWorks products:**

- » MATLAB®
- » Simulink®
- » MATLAB Coder™
- » Simulink Coder™
- » Simulink Real-Time™

**speedgoat**  
real-time simulation and testing

Speedgoat GmbH  
Waldeggstrasse 30  
3097 Liebfeld  
Switzerland  
[www.speedgoat.com](http://www.speedgoat.com)



Flugwissenschaftliche  
Vereinigung Aachen (1920) e.V.

Templergraben 55  
52056 Aachen  
Germany

[www.fva.rwth-aachen.de](http://www.fva.rwth-aachen.de)

[Read more success stories](http://www.speedgoat.com/success-stories)  
[www.speedgoat.com/success-stories](http://www.speedgoat.com/success-stories)