

Combining FEM-Based Torque Ripple and Switching Inverter Dynamics for Electric Drive Controller Validation on Speedgoat Test Systems

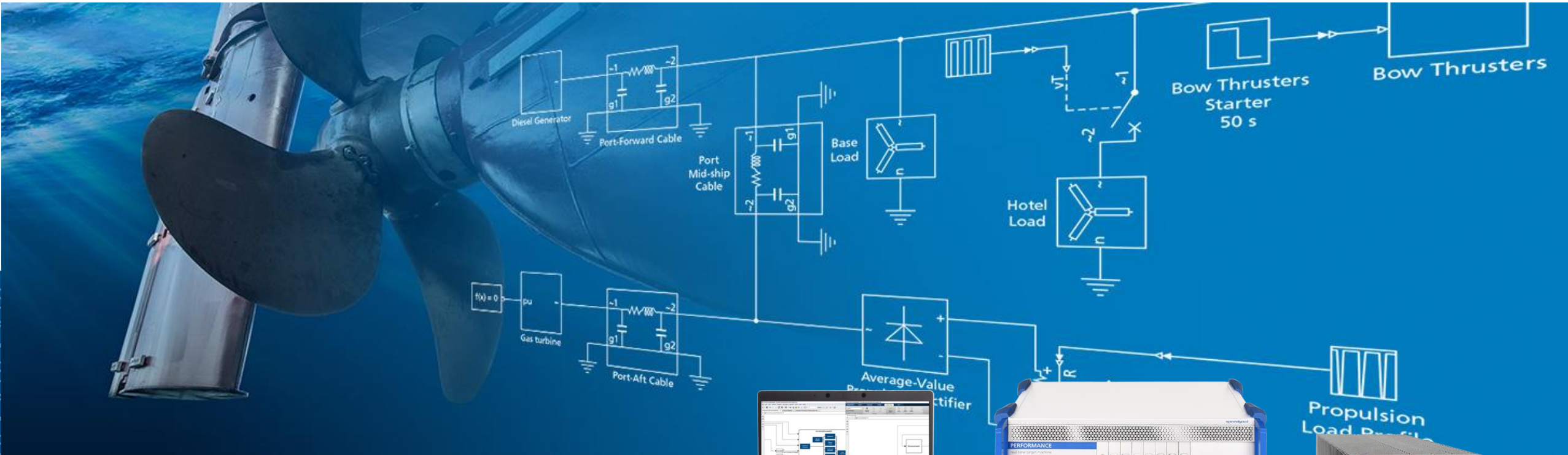

Dr. Mathieu Lu-Dac, Senior Application Engineer

December 3rd, 2025 | Tokyo, Japan



About Speedgoat

- An associate company of
- Founded in 2006 in Switzerland
- Main offices
 - Speedgoat GmbH Switzerland (HQ)
 - Speedgoat GmbH Germany
 - Speedgoat Inc USA
- MIS Corporation
 - Distribution Partner in Japan



www.speedgoat.com/contact-us

About Speedgoat

- Provider of real-time test systems, expressly designed for use with Simulink®

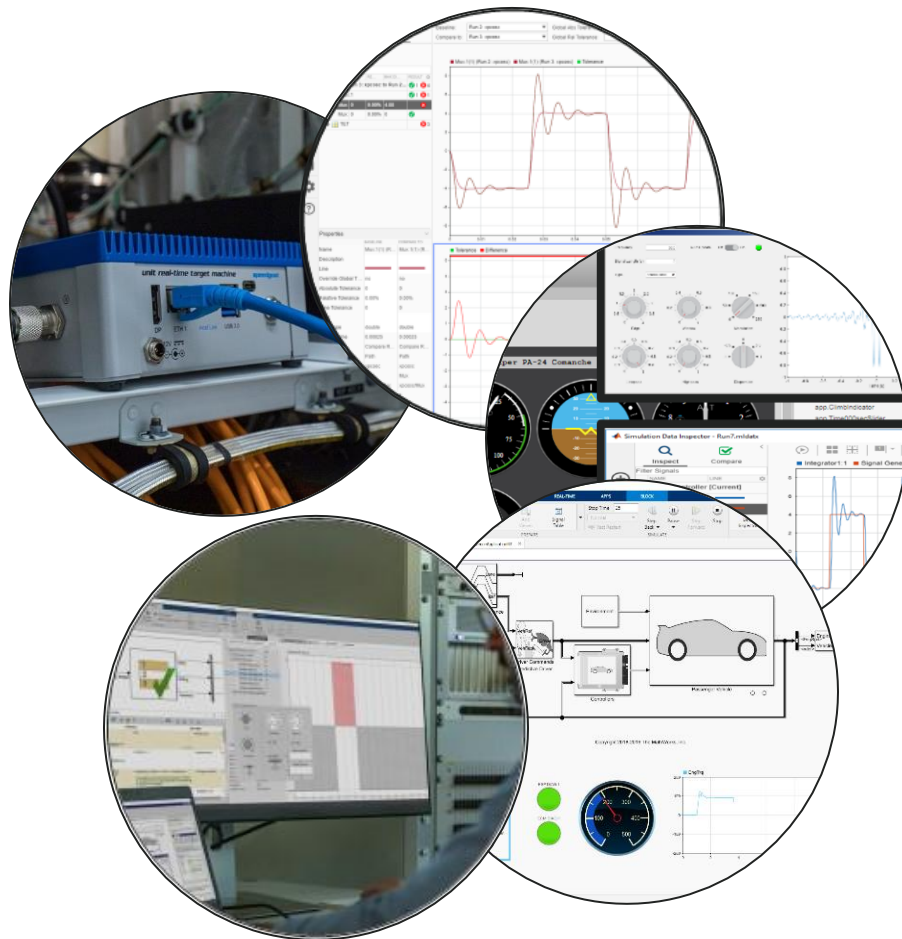

Real-Time Testing with Speedgoat :



MathWorks®
Simulink® Real-Time™ (SLRT)



Speedgoat
Real-Time Test Systems

- › Modeling ecosystem
- › Real-time instrumentation
- › Automated testing
- › Code generation (C/VHDL)

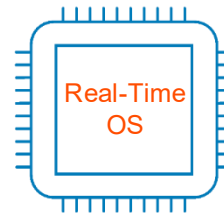

- › I/O & protocol support
- › FPGA-based solutions
- › Speedgoat I/O blockset
- › Complete racks

Managing Torque Ripples

- Torque ripple is a critical challenge in motor drive developments
 - Source of instability for precision controls
 - Source of vibrations for NVH optimizations
- Torque ripples have different contributors
 - Motor topology (slot opening, saturation)
 - Motor manufacturing process
 - Switching dynamics of inverter
 - Controller algorithm
 - System level (load, resonances etc.)
- Torque ripples can be addressed at different stages of the development
 - Reduction of spatial harmonics in FEM
 - Tuning of controller parameters in simulation
 - Controlling and optimizing manufacturing imperfections in RCP
 - HIL testing for hardware and production code verification

Development Journey

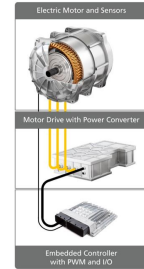
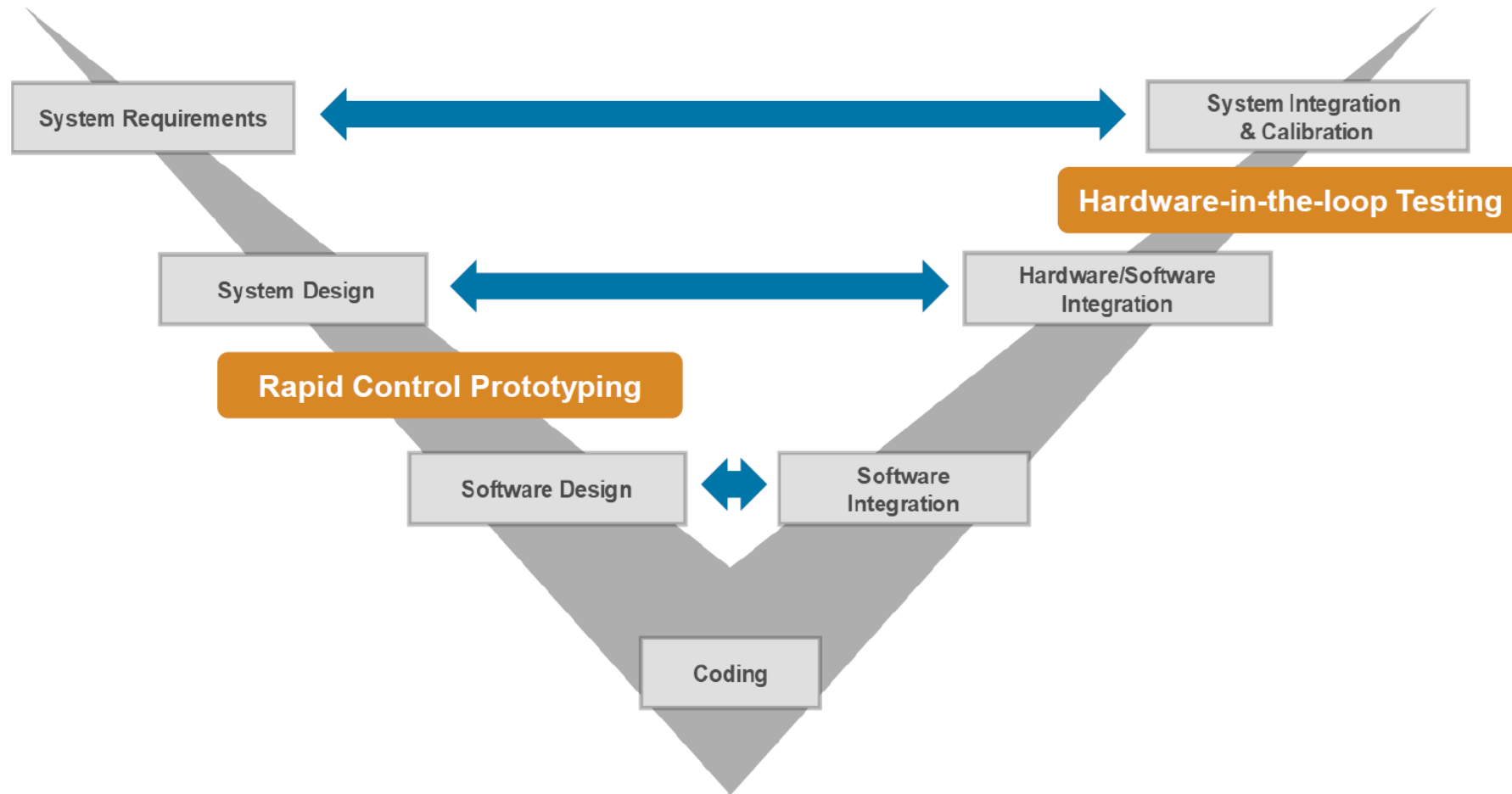

Final Product

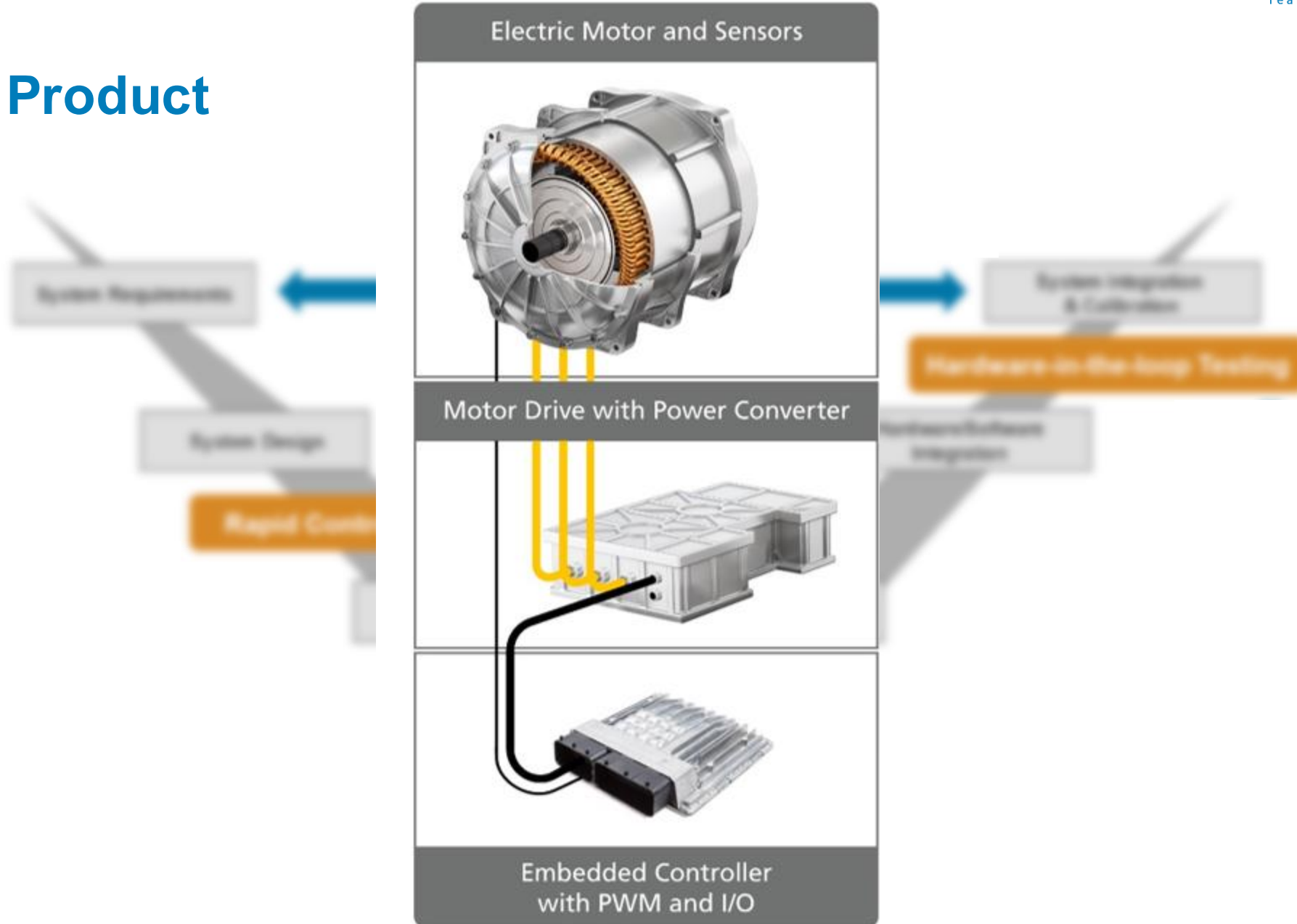

Development Journey

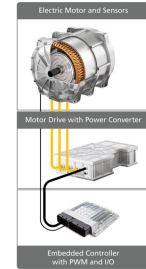
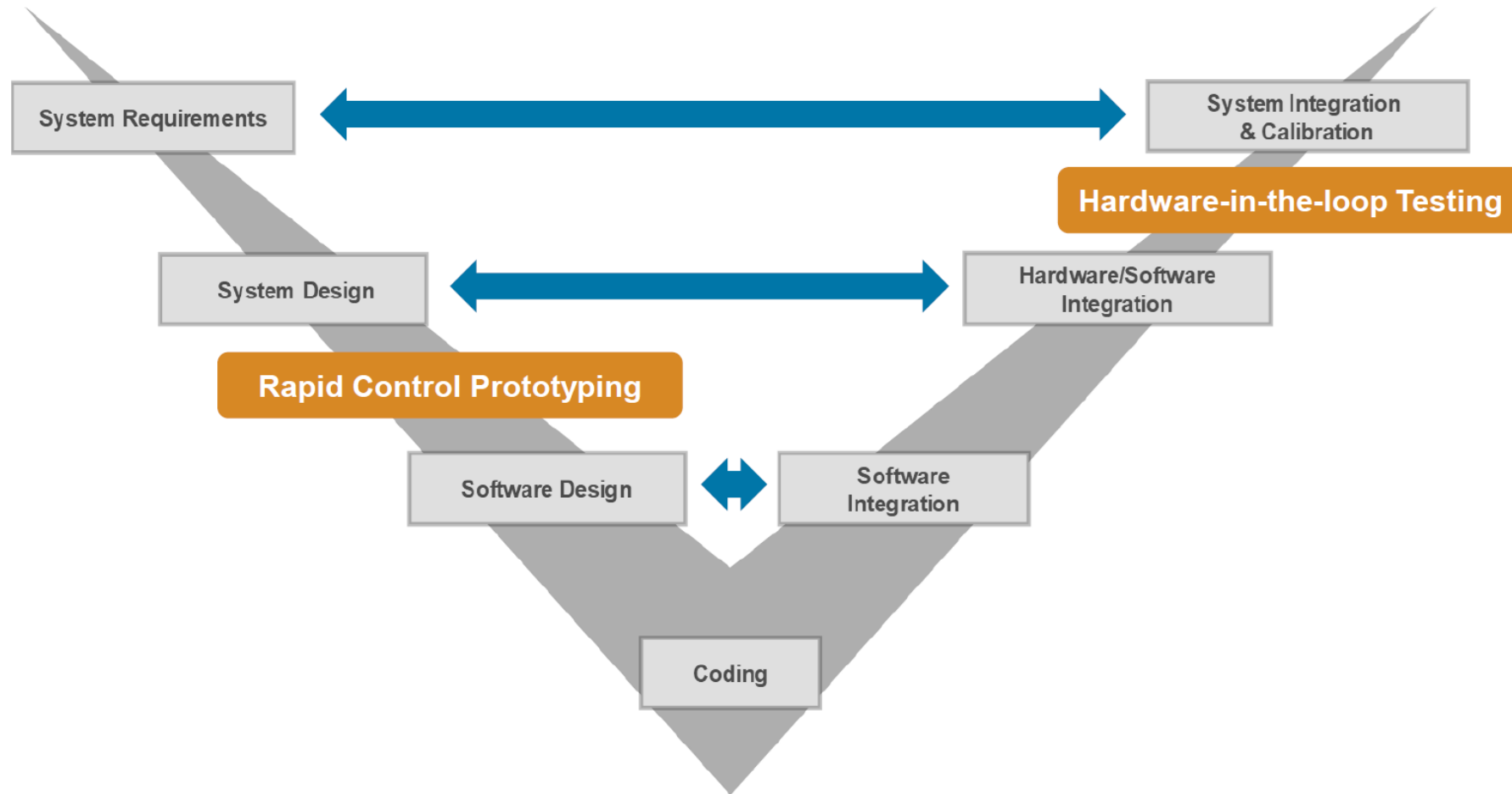

Development Journey

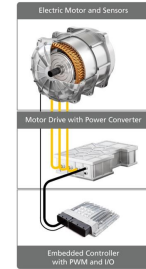
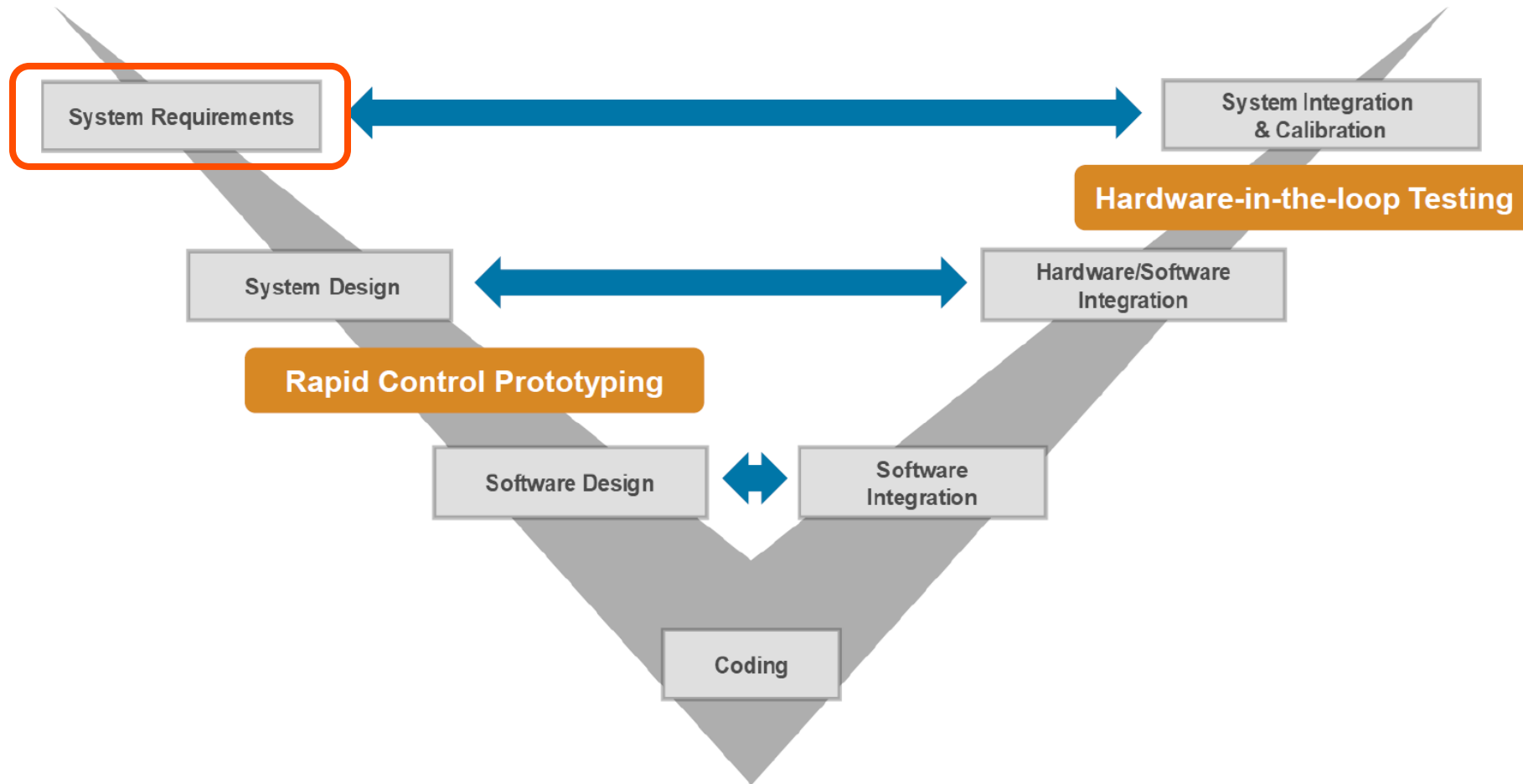

Requirement management

- Start by defining the requirements from a system level perspective

The screenshot shows the Requirements Editor application window. On the left, there is a sidebar with 'External Requirements' (doc and xls files) and 'Requirements Management Tools' (database icon). A blue arrow points from the external requirements to the main table. The main area contains a table with columns for 'Summary', 'Verified', and 'Implemented'. The 'Implemented' column uses progress bars to show completion status. On the right, a 'Properties' panel is visible, showing details for a selected requirement, including its type, index, custom ID, and summary.

Summary	Verified	Implemented
Speed	<div style="width: 100%; background-color: yellow;"></div>	<div style="width: 100%; background-color: blue;"></div>
Speed and acceleration	<div style="width: 100%; background-color: yellow;"></div>	<div style="width: 100%; background-color: blue;"></div>
Stability	<div style="width: 100%; background-color: yellow;"></div>	<div style="width: 100%; background-color: blue;"></div>
Torque	<div style="width: 100%; background-color: yellow;"></div>	<div style="width: 100%; background-color: blue;"></div>
Torque Ripple	<div style="width: 0%; background-color: yellow;"></div>	<div style="width: 100%; background-color: blue;"></div>

Properties

Type: Functional

Index: 5

Custom ID: 5. Max Torque Ripple

Summary: The torque ripple shall not exceed 0.3Nm at the nominal speed (rpm).

Description: NVH requirements for the system

Requirement management

- Start by defining the requirements from a system level perspective
- Track verification and implementation

The screenshot shows the Requirements Editor application window. The interface includes a menu bar with options like FILE, PROFILE, REQUIREMENTS, LINKS, VIEW, EDIT, ANALYSIS, and SHARE. Below the menu is a toolbar with icons for various actions. The main workspace contains a table of requirements and a properties panel on the right.

Index	ID	Summary	Verified	Implemented
1	1. Min Top Speed	The motor drive shall reach at least 1000 rpm	<div style="width: 100%; height: 10px; background-color: yellow;"></div>	<div style="width: 100%; height: 10px; background-color: blue;"></div>
2	2. Min Speed and acceleration	The motor Drive Shall reach at lest 500 RPM in less than 5s	<div style="width: 100%; height: 10px; background-color: yellow;"></div>	<div style="width: 100%; height: 10px; background-color: blue;"></div>
3	3. Speed Stability	The speed shall always be within 10% of the command	<div style="width: 100%; height: 10px; background-color: yellow;"></div>	<div style="width: 100%; height: 10px; background-color: blue;"></div>
4	4. Min Torque	The Motor shall provide a minimum of 3Nm	<div style="width: 100%; height: 10px; background-color: yellow;"></div>	<div style="width: 100%; height: 10px; background-color: blue;"></div>
5	5. Max Torque Ripple	The torque ripple shall not exceed 0.3Nm at the nominal speed (rpm).	<div style="width: 0%; height: 10px; background-color: yellow;"></div>	<div style="width: 100%; height: 10px; background-color: blue;"></div>

Properties

Type: Functional

Index: 5

Custom ID: 5. Max Torque Ripple

Summary: The torque ripple shall not exceed 0.3Nm at the nominal speed (rpm).

Description: NVH requirements for the system

System Design and Simulation

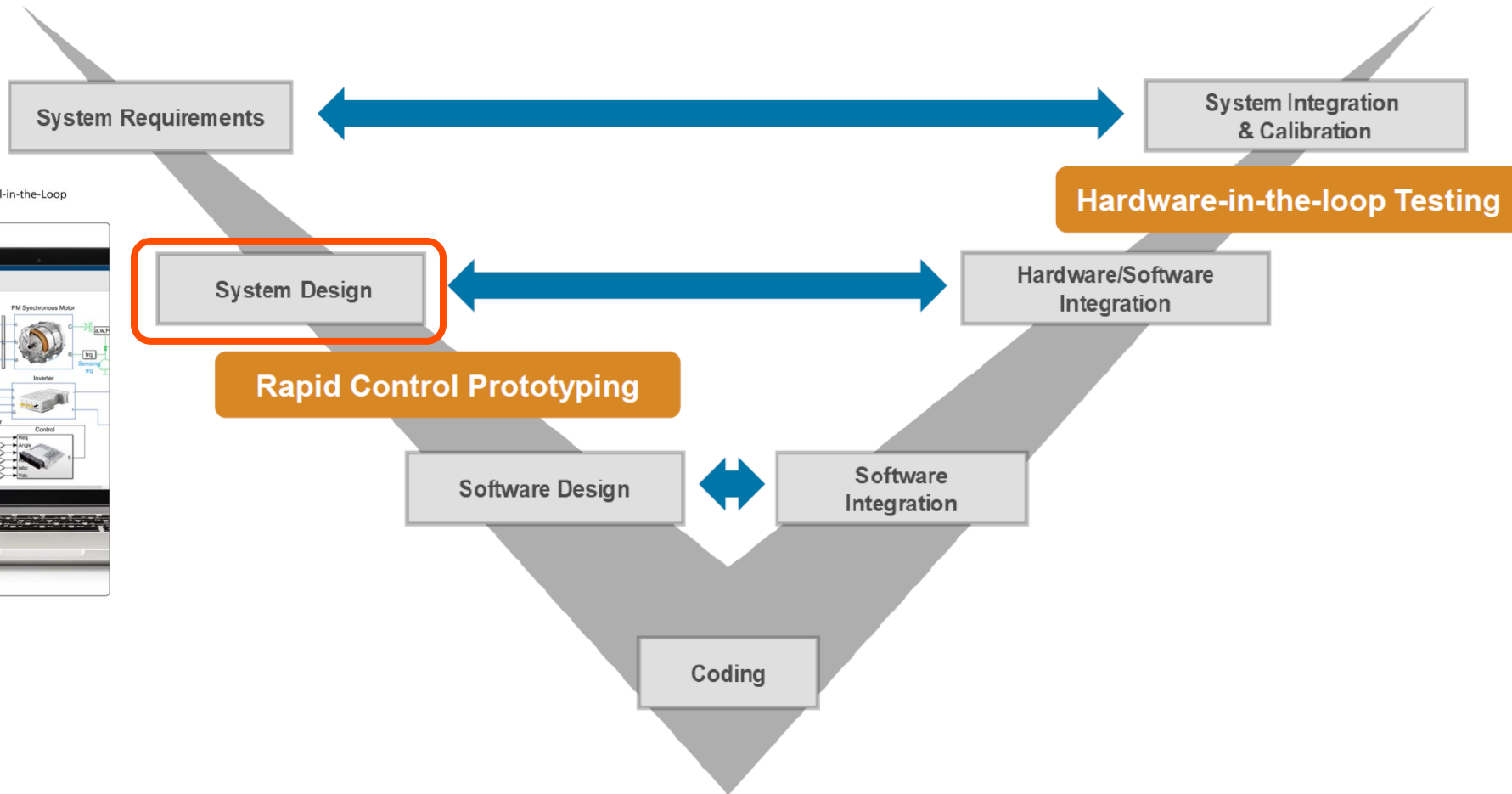
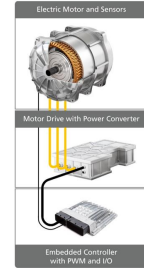
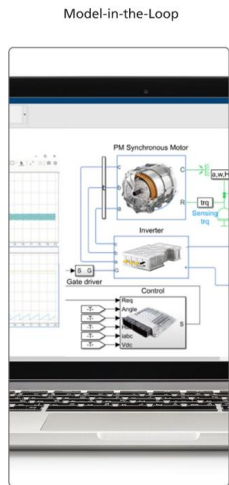

System Design and Simulation

Model-in-the-Loop

JMAG-Designer

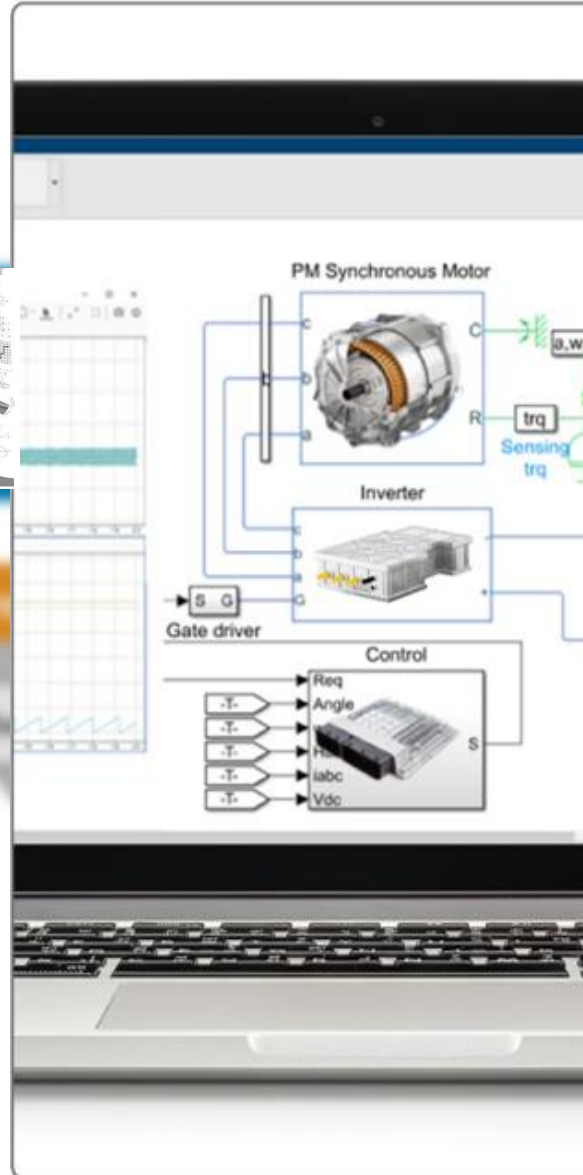
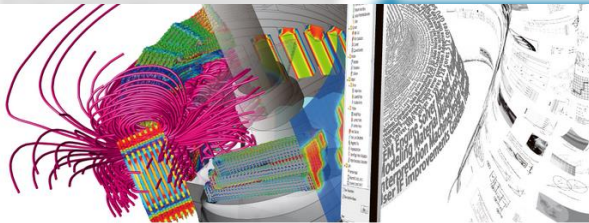

Enabled by
**MATLAB®
& SIMULINK®**
MathWorks®

Model-in-the-Loop

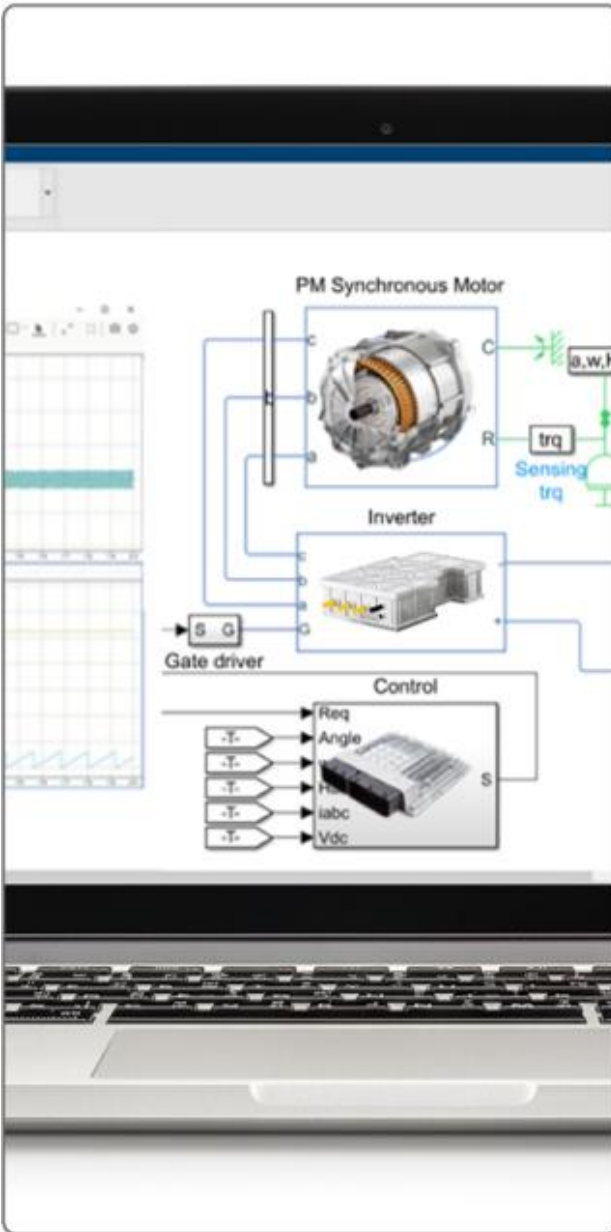
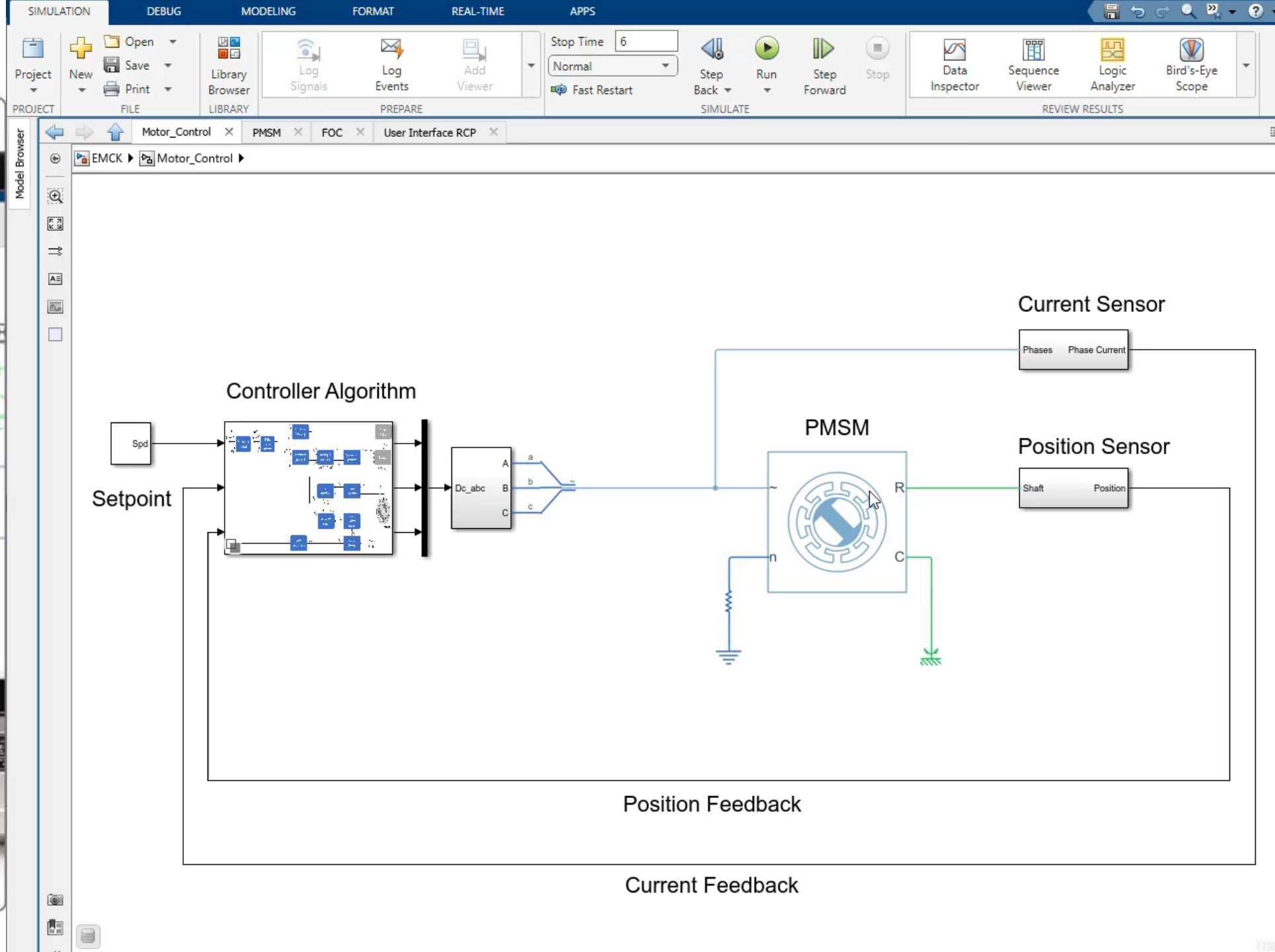

Simulating Torque Ripple Effects

- FEA calculations of saturation and slot opening contributions

JMAG

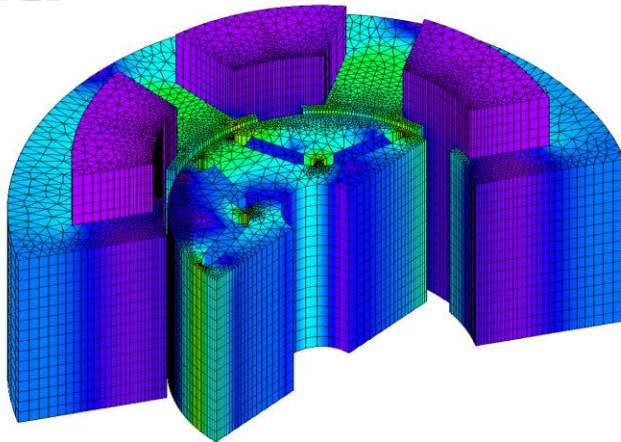

JMAG-Express Online

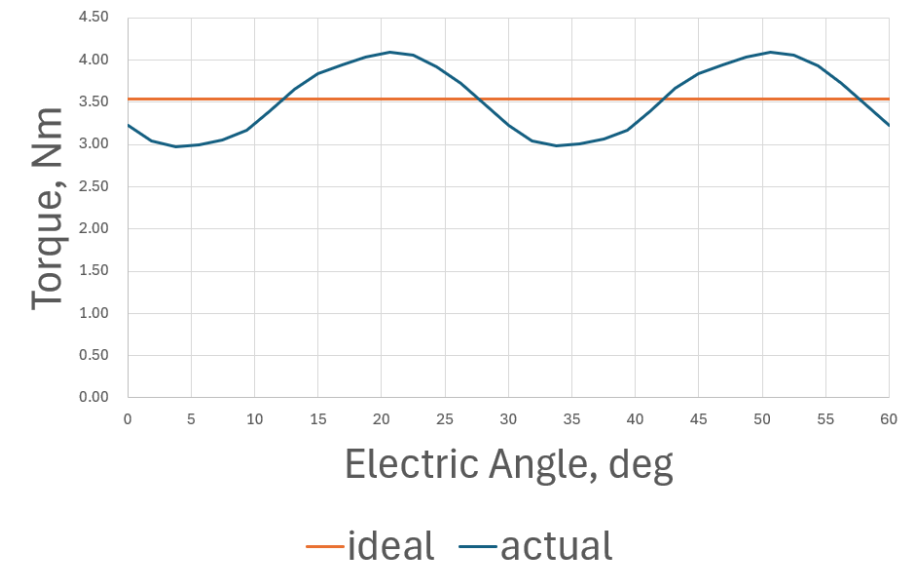
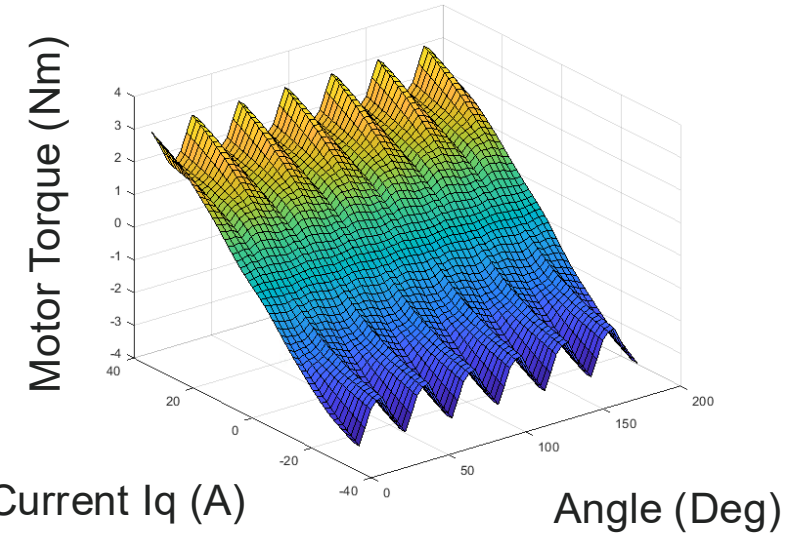
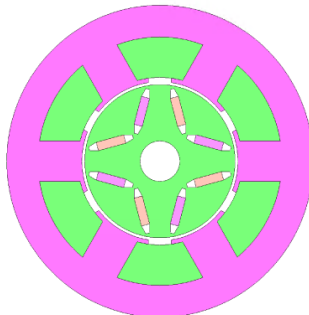

Simulating Torque Ripple Effects

- Including FEA results in Simulink® and Simscape® for controller and multiphysics simulations

JMAG

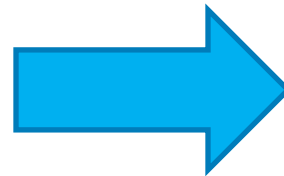
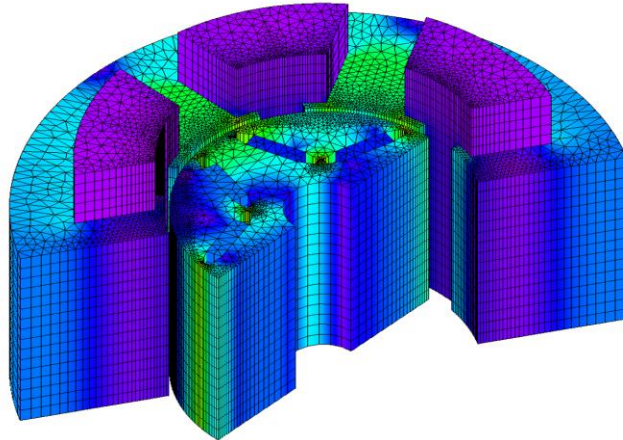

JMAG-Express Online

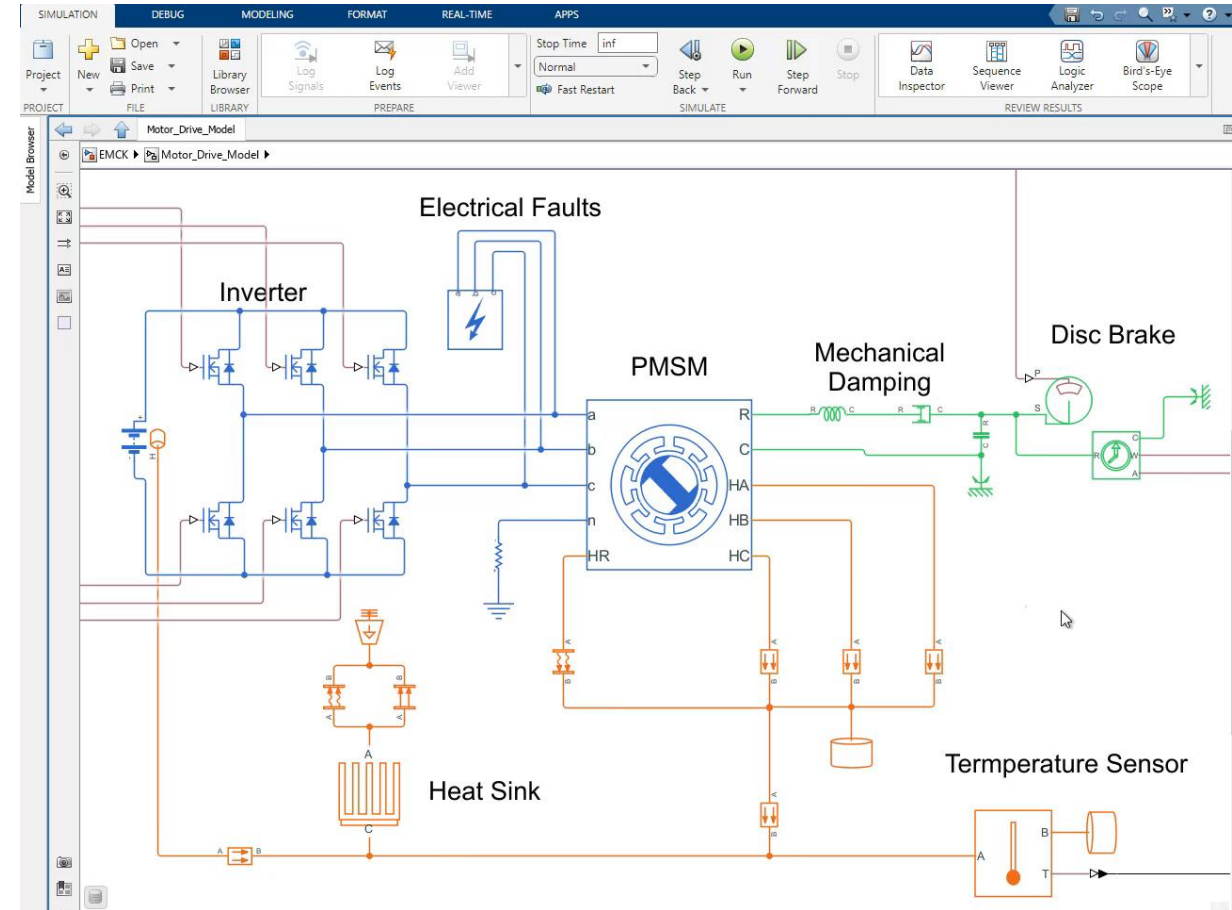
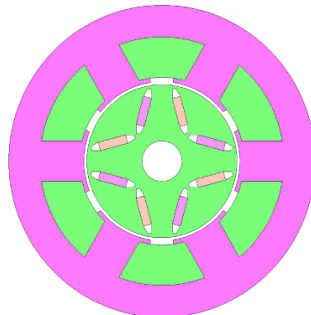

Simulating Torque Ripple Effects

- Including FEA results in Simulink® and Simscape®

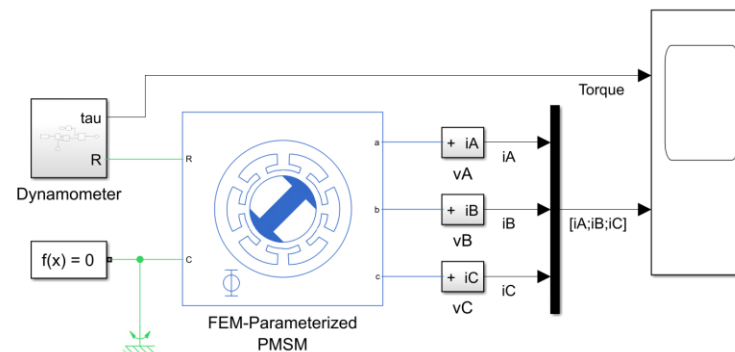
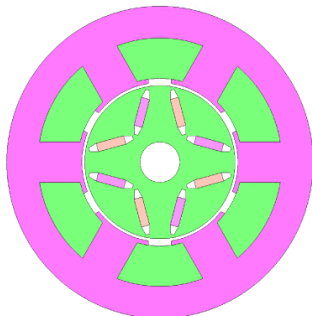
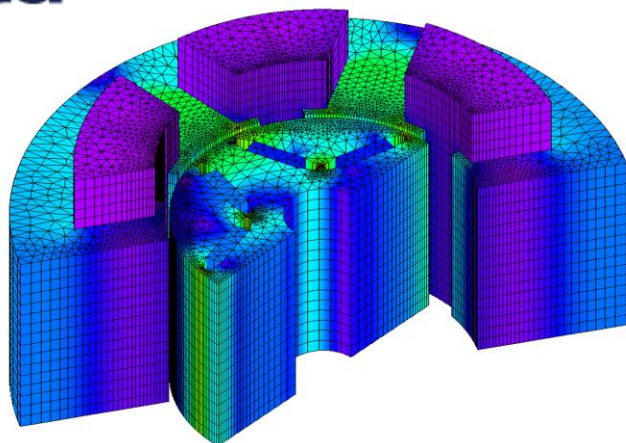

Import PMSM Flux Linkage Data from JMAG-RT

1. Load motor data from JMAG ([open script](#), [run script](#))
2. [Plot results](#) in motor windings ([see code](#))
3. [Explore simulation results](#) using [Simscape Results Explorer](#)
4. [Learn more](#) about this example

Copyright 2022-2023 The MathWorks, Inc.

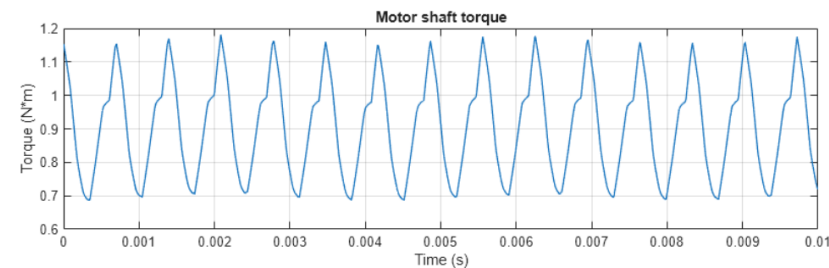
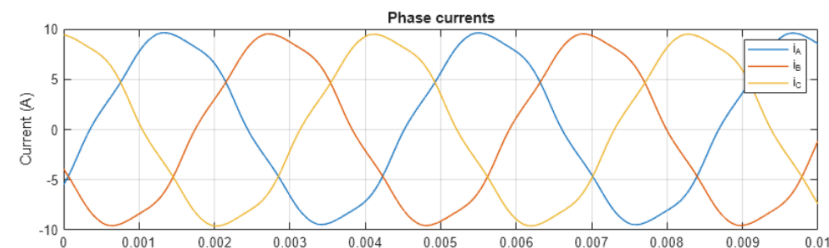

Simulating Torque Ripple Effects

- Typical FOC controllers can be tuned automatically using Simulink®

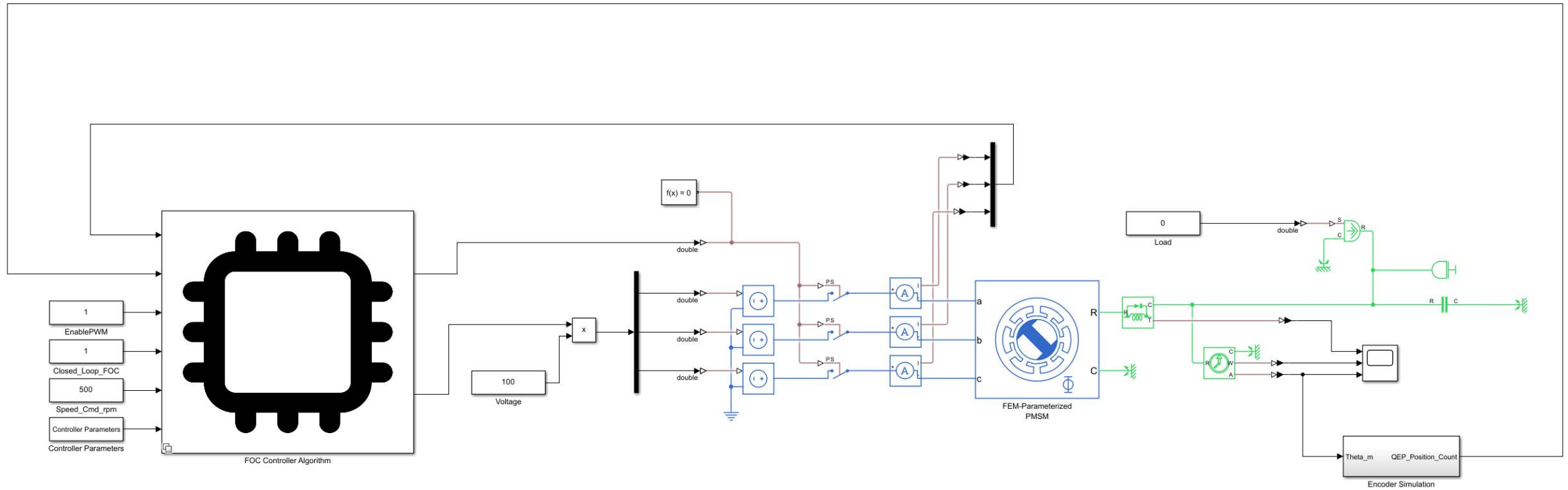

System Design and Simulations

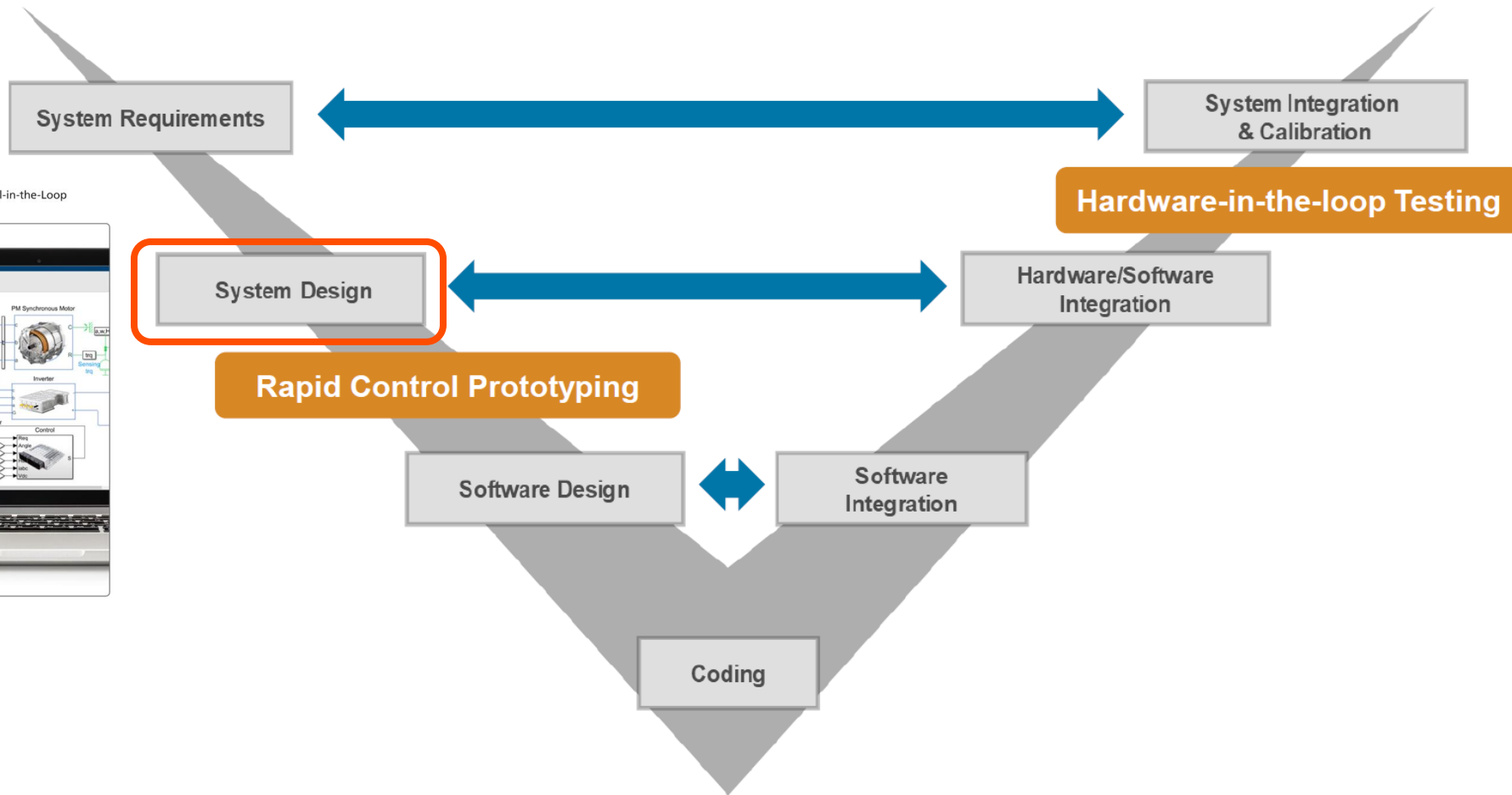
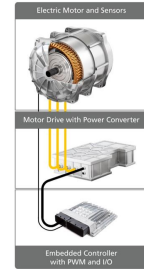
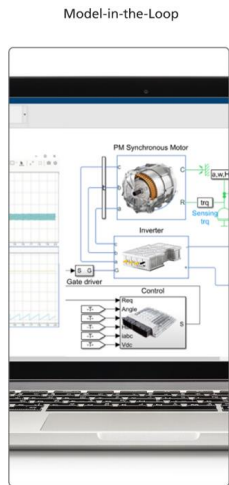

Rapid Control Prototyping

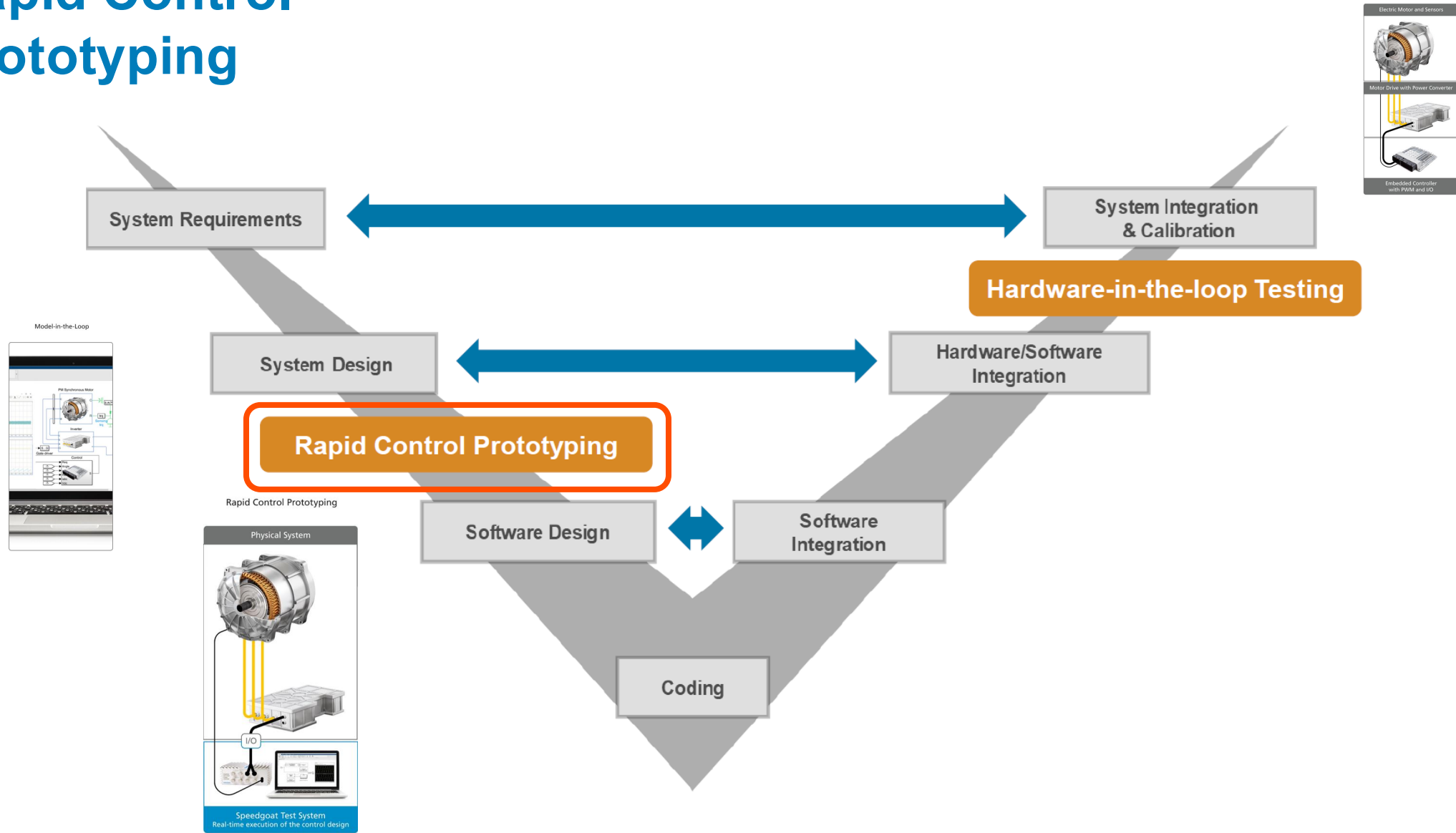

Rapid Control Prototyping

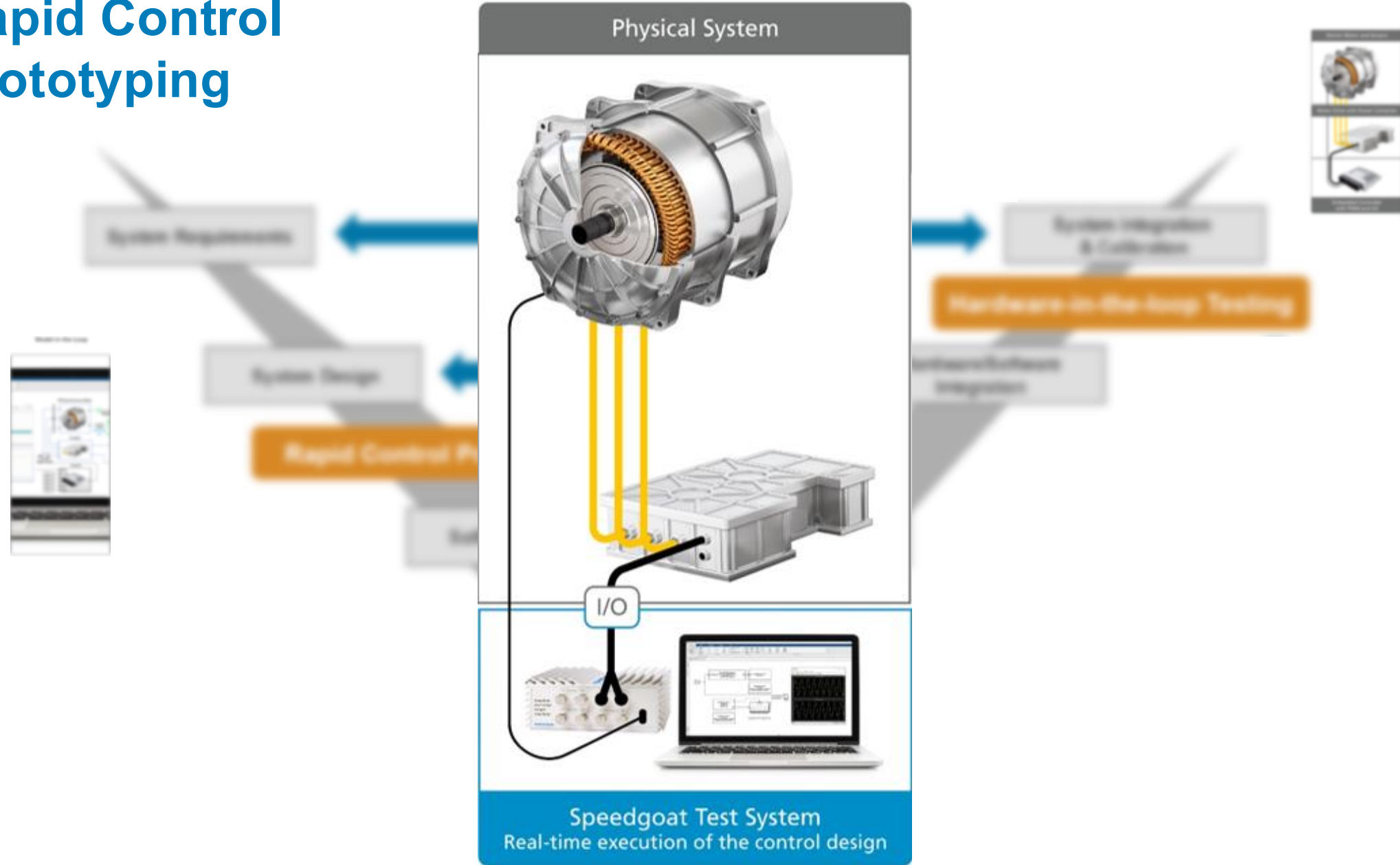

Rapid Control Prototyping

Physical System

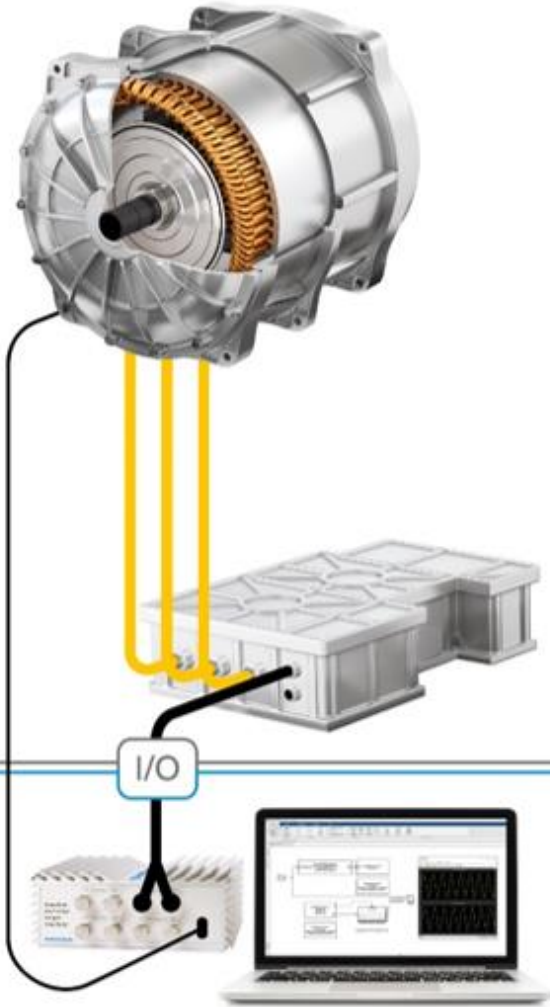

Speedgoat Test System
Real-time execution of the control design

Rapid Control Prototyping

Physical System



Speedgoat Test System
Real-time execution of the control design

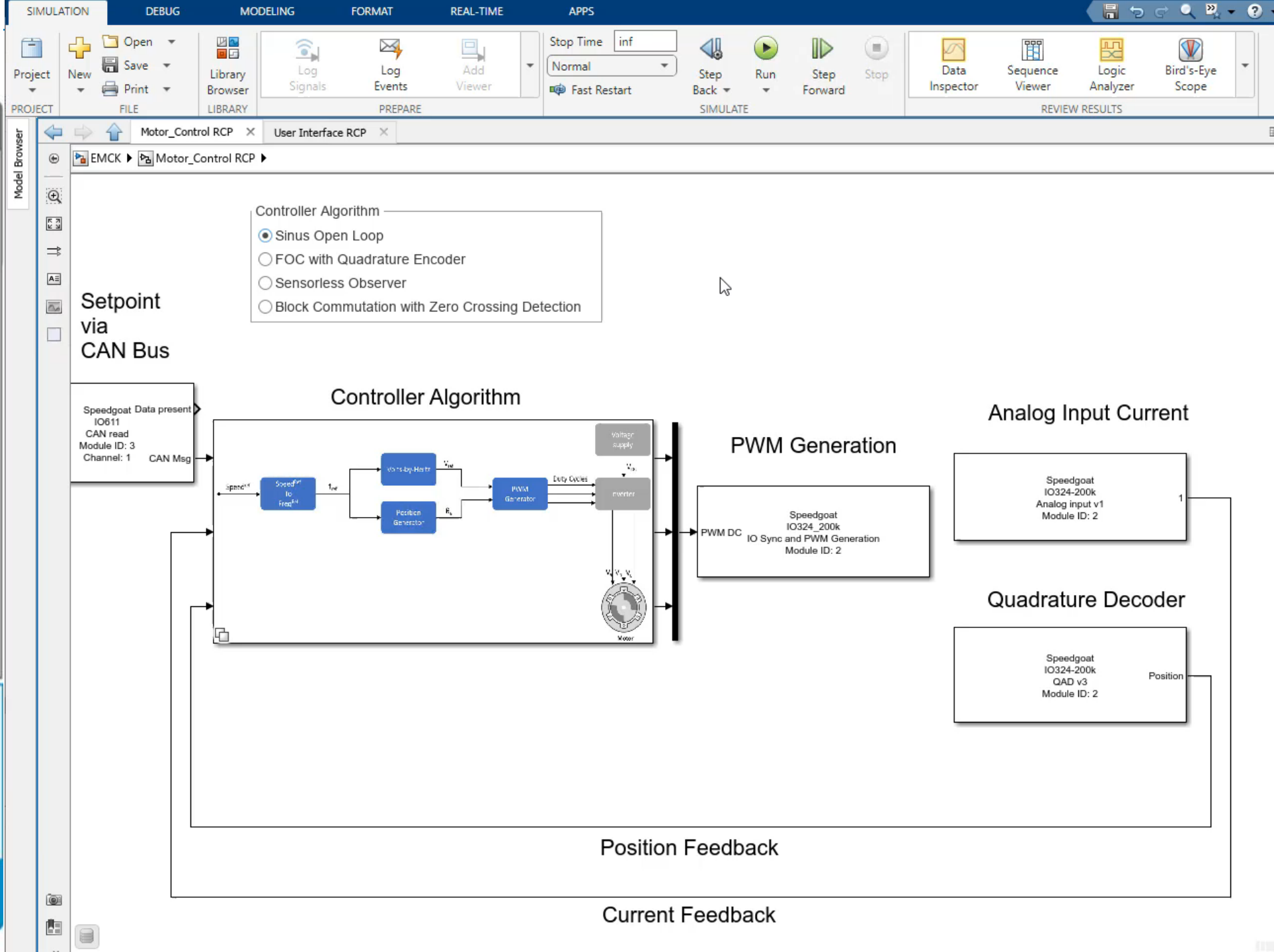

Development Journey

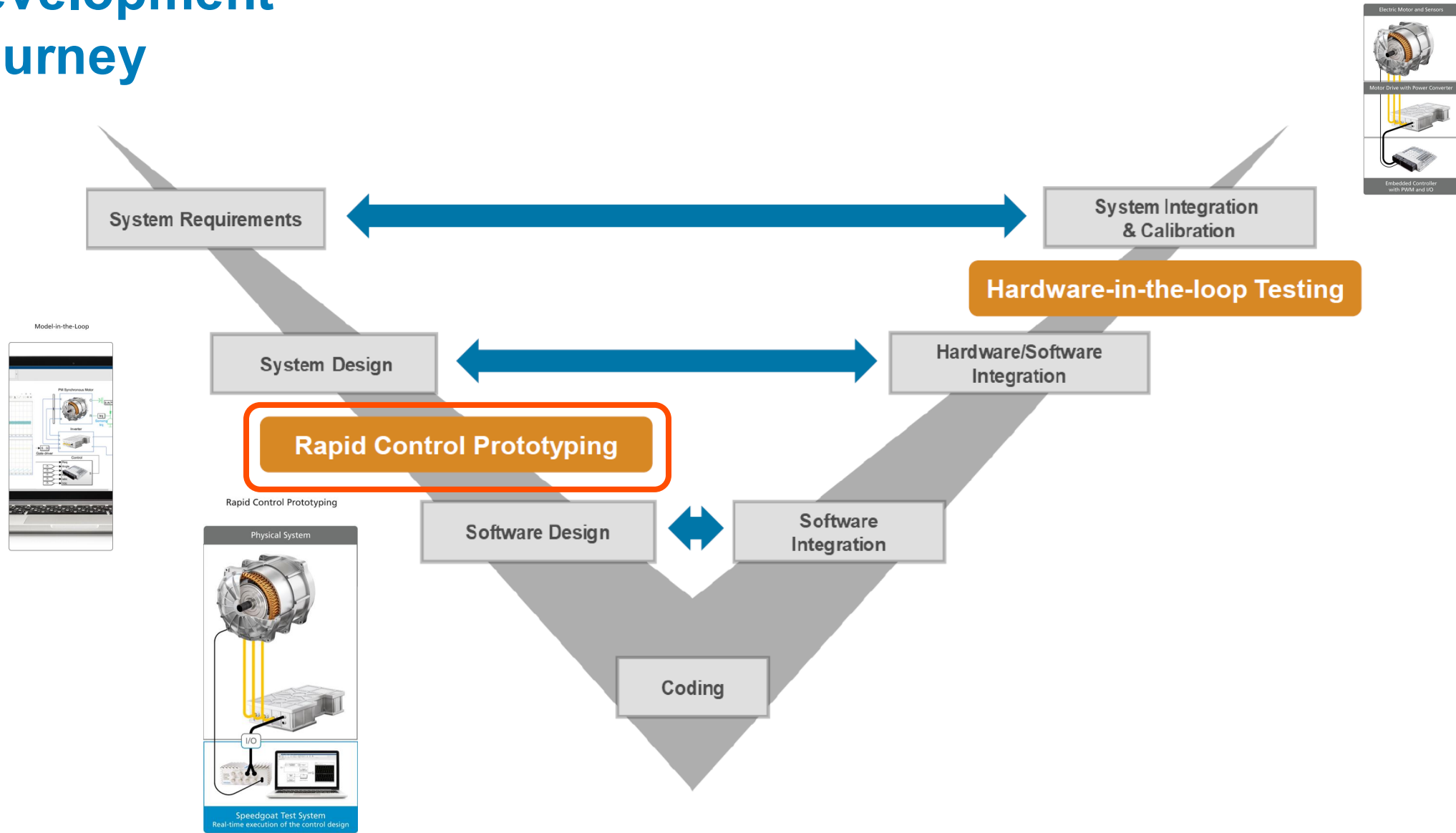

Development Journey

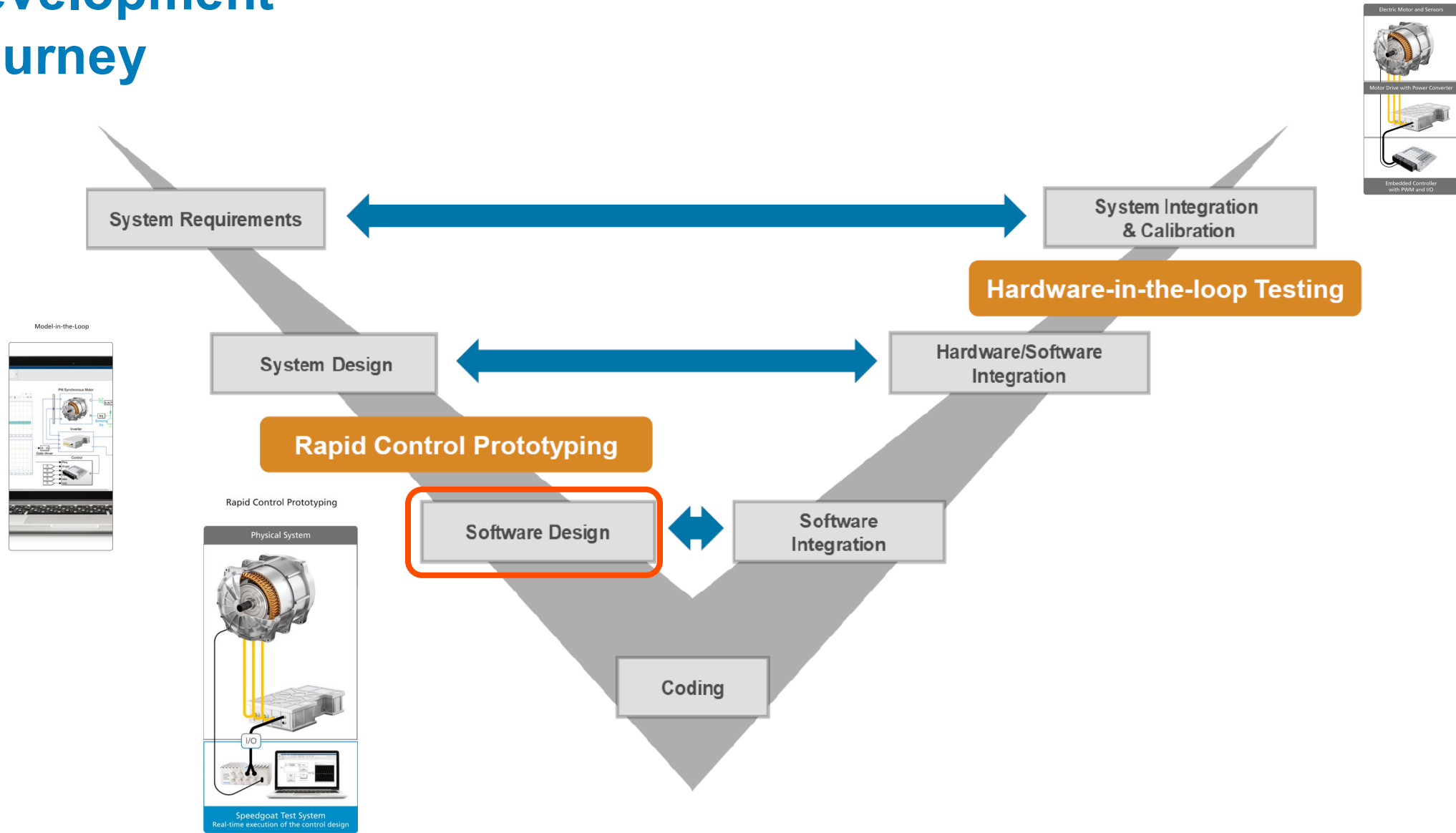

Development Journey

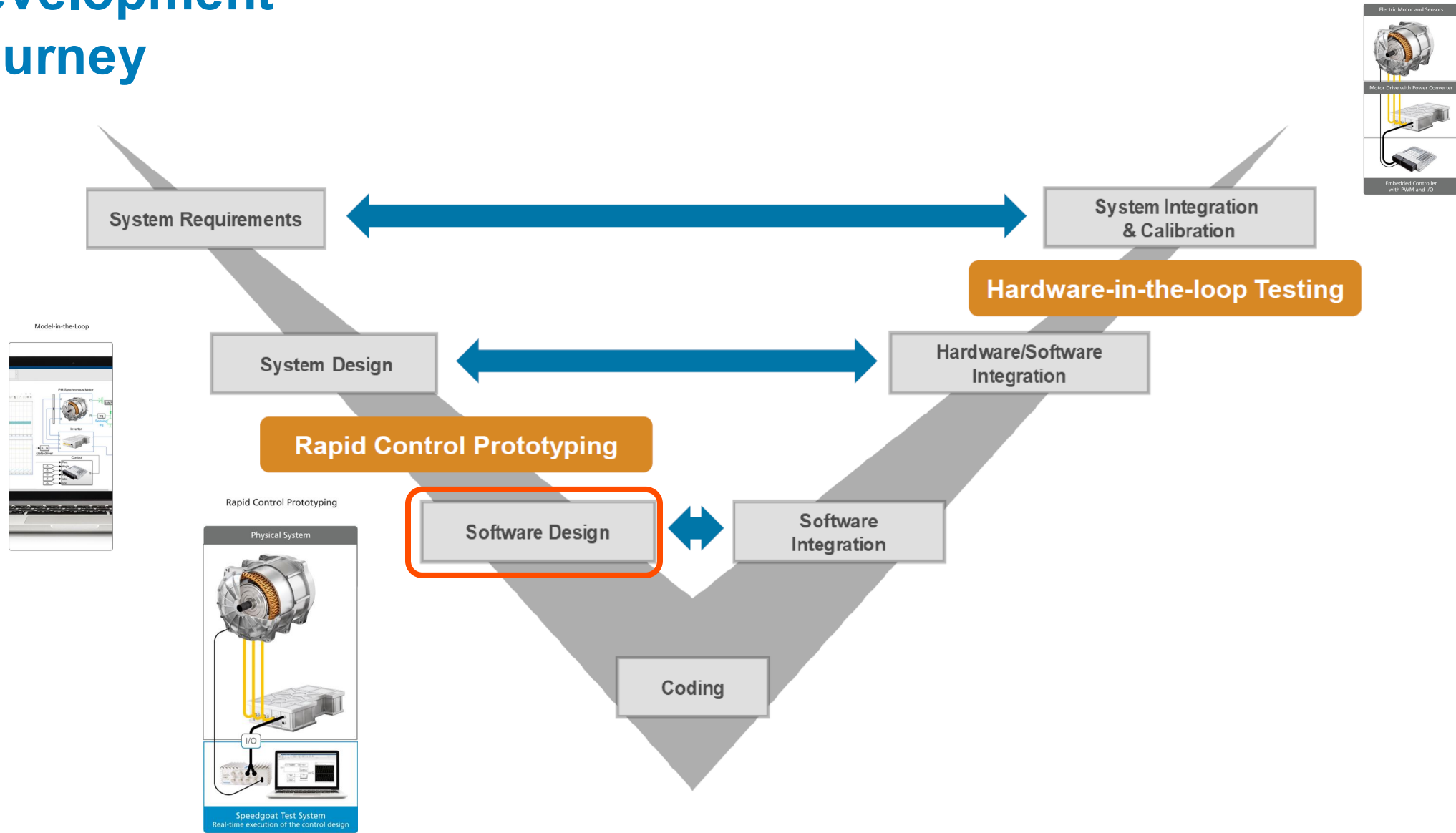

Development Journey

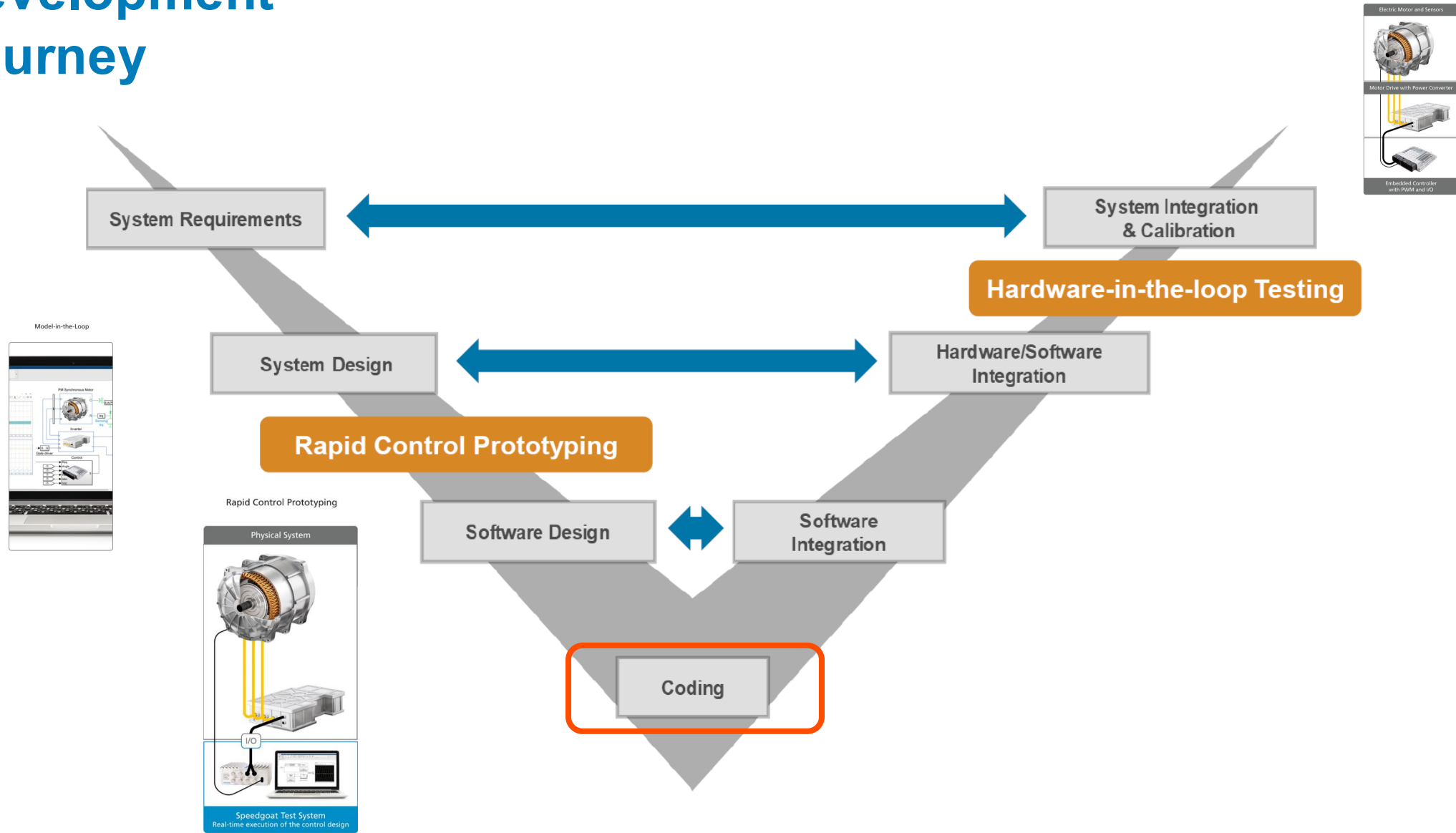

Development Journey

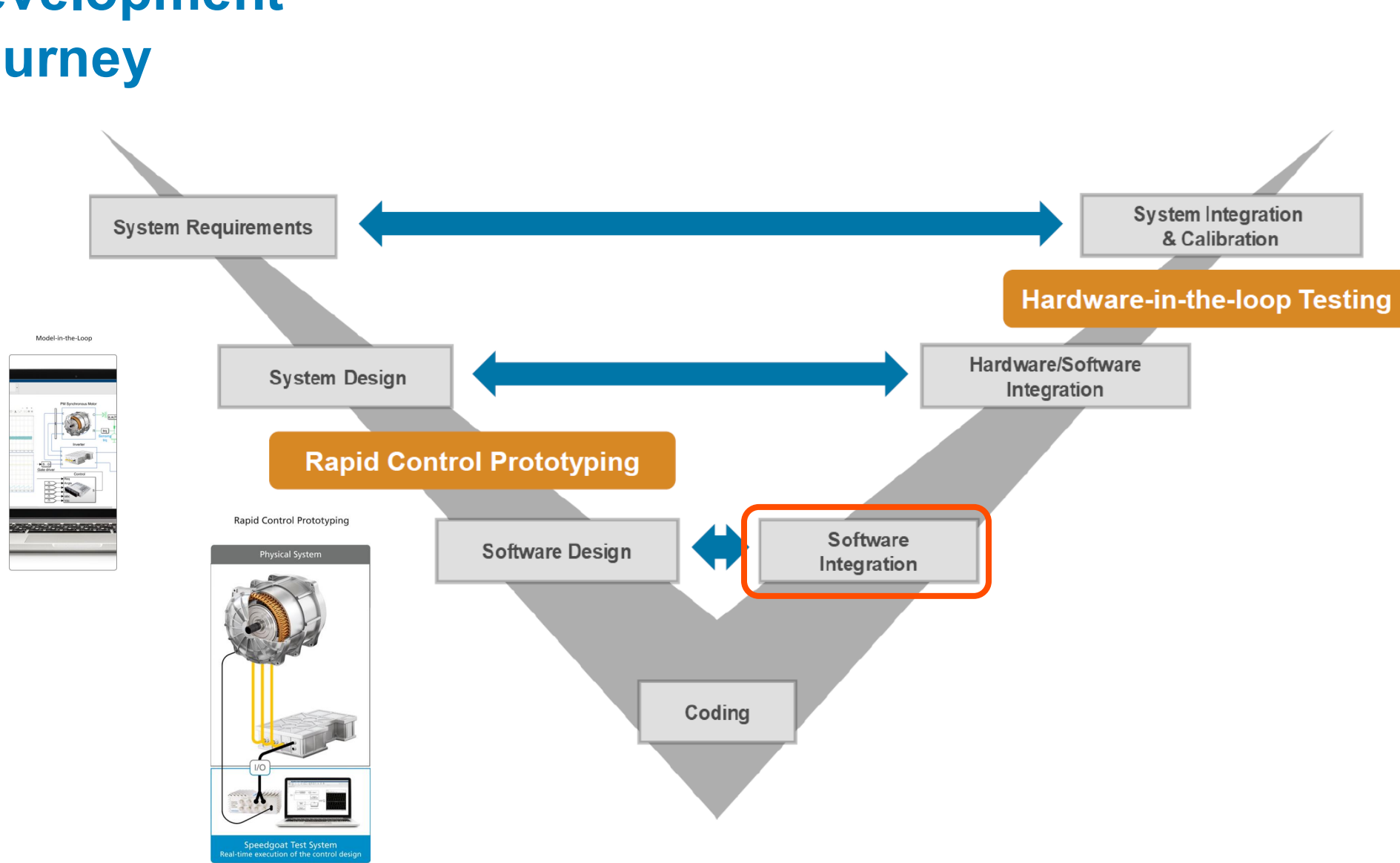

SIMULATION DEBUG MODELING FORMAT **HARDWARE** APPS SUBSYSTEM BLOCK

Hardware Board: TI Delfino F28379D LaunchPad

Run on board | Hardware Settings | Hardware Mapping | Log Signals | Add Viewer

Stop Time: Inf | Monitor & Tune | Data Inspector | Logic Analyzer | Performance Report

Build, Deploy & Start (highlighted) | DEPLOY

HARDWARE BOARD MODE PREPARE RUN ON HARDWARE REVIEW RESULTS

Field-Oriented Control for PMSM

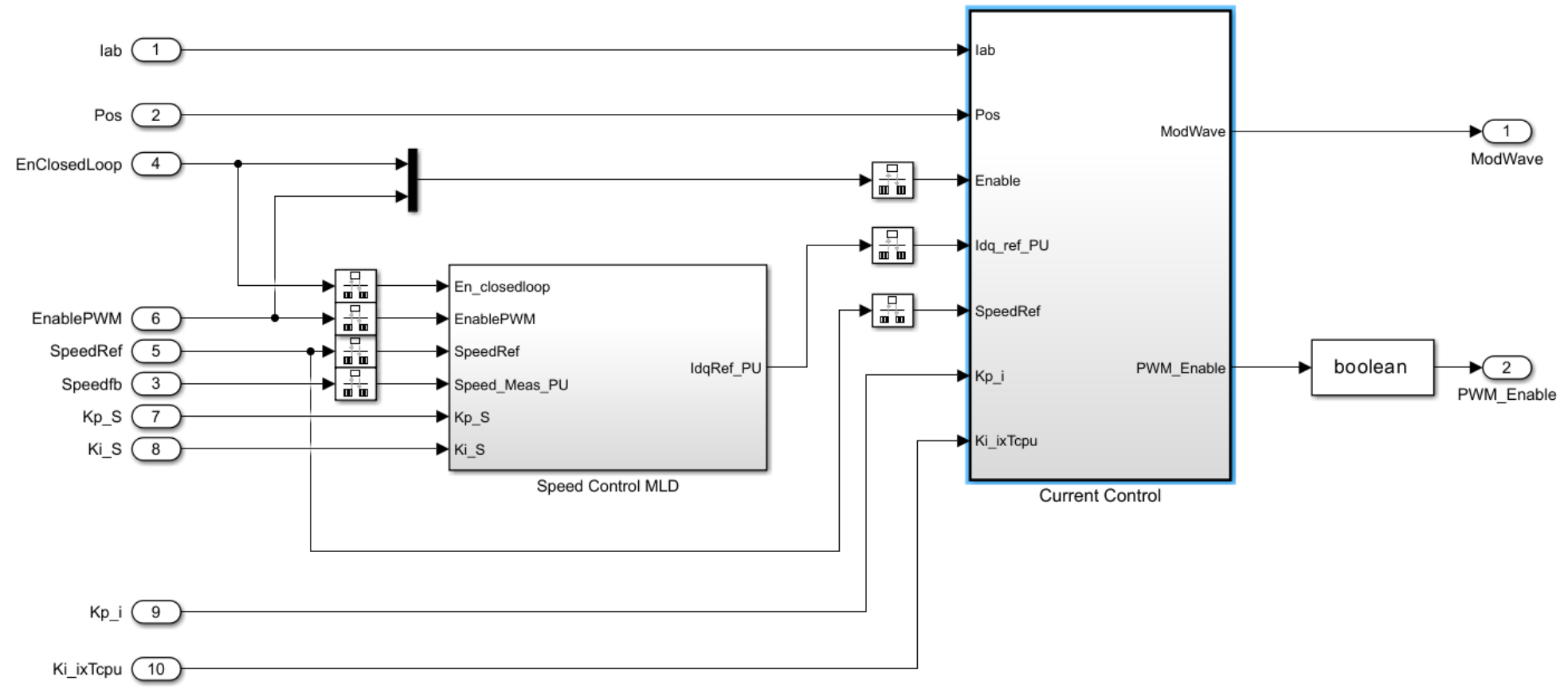

Development Journey

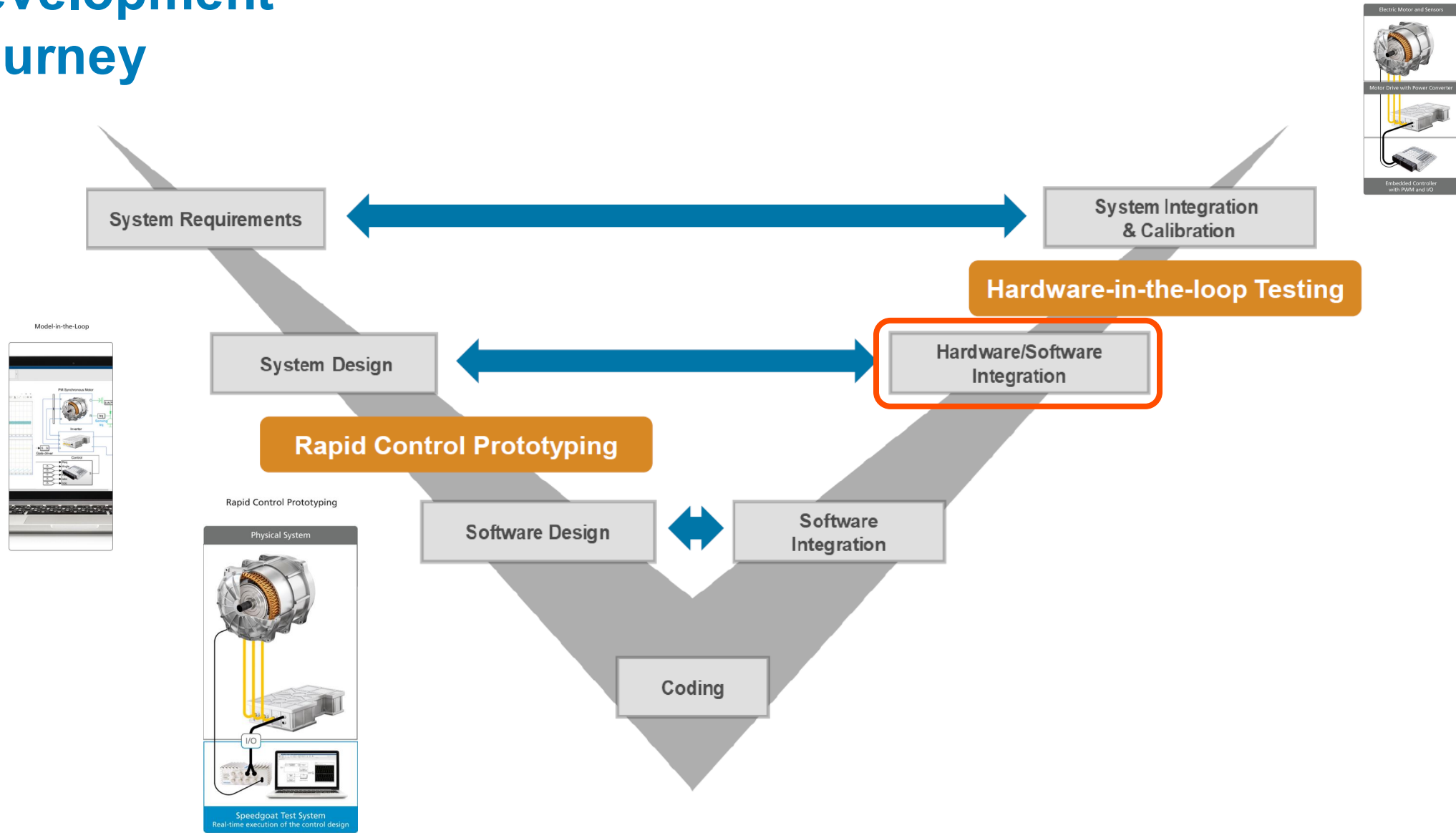

Development Journey

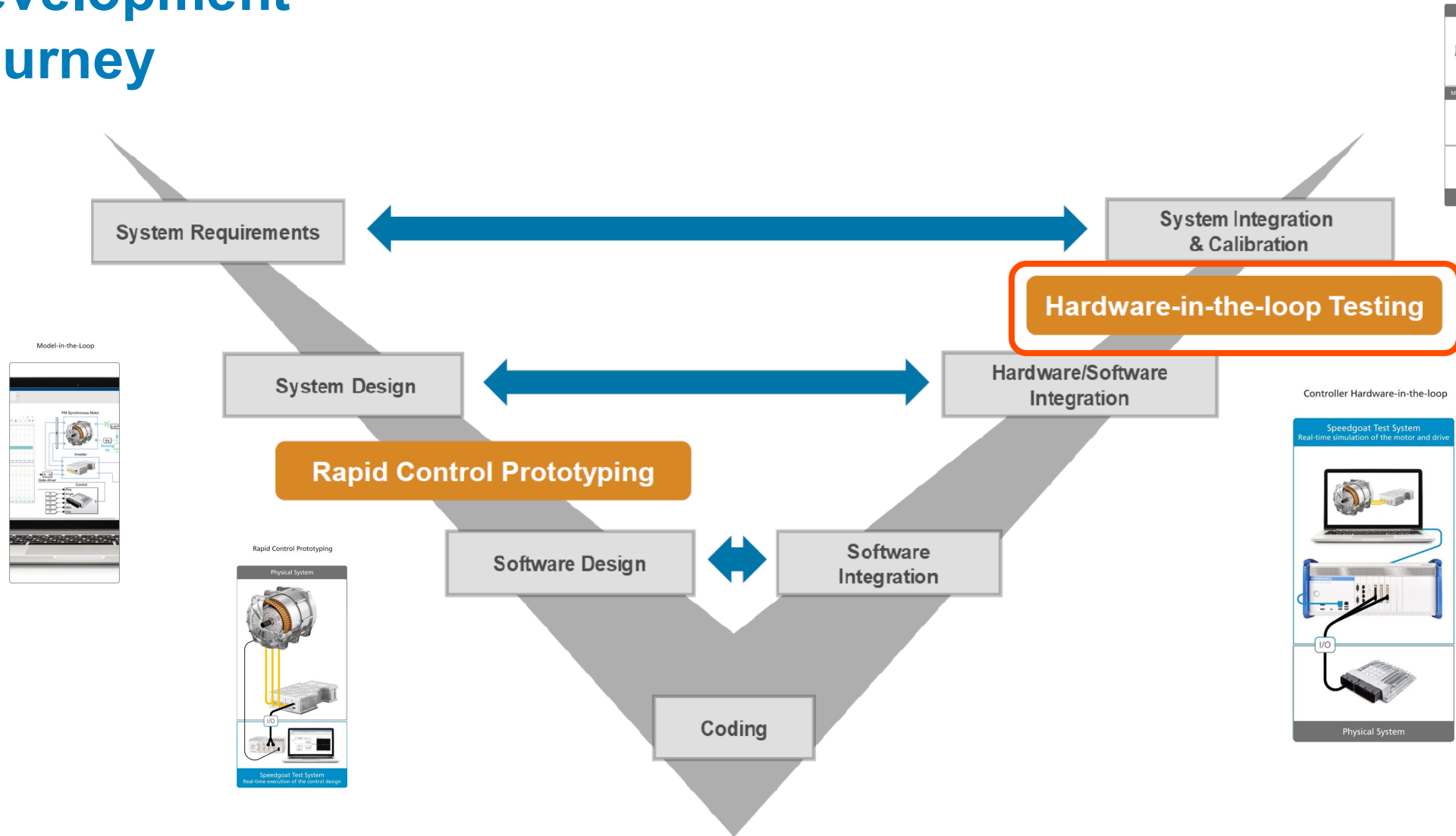

Hardware In the Loop Testing

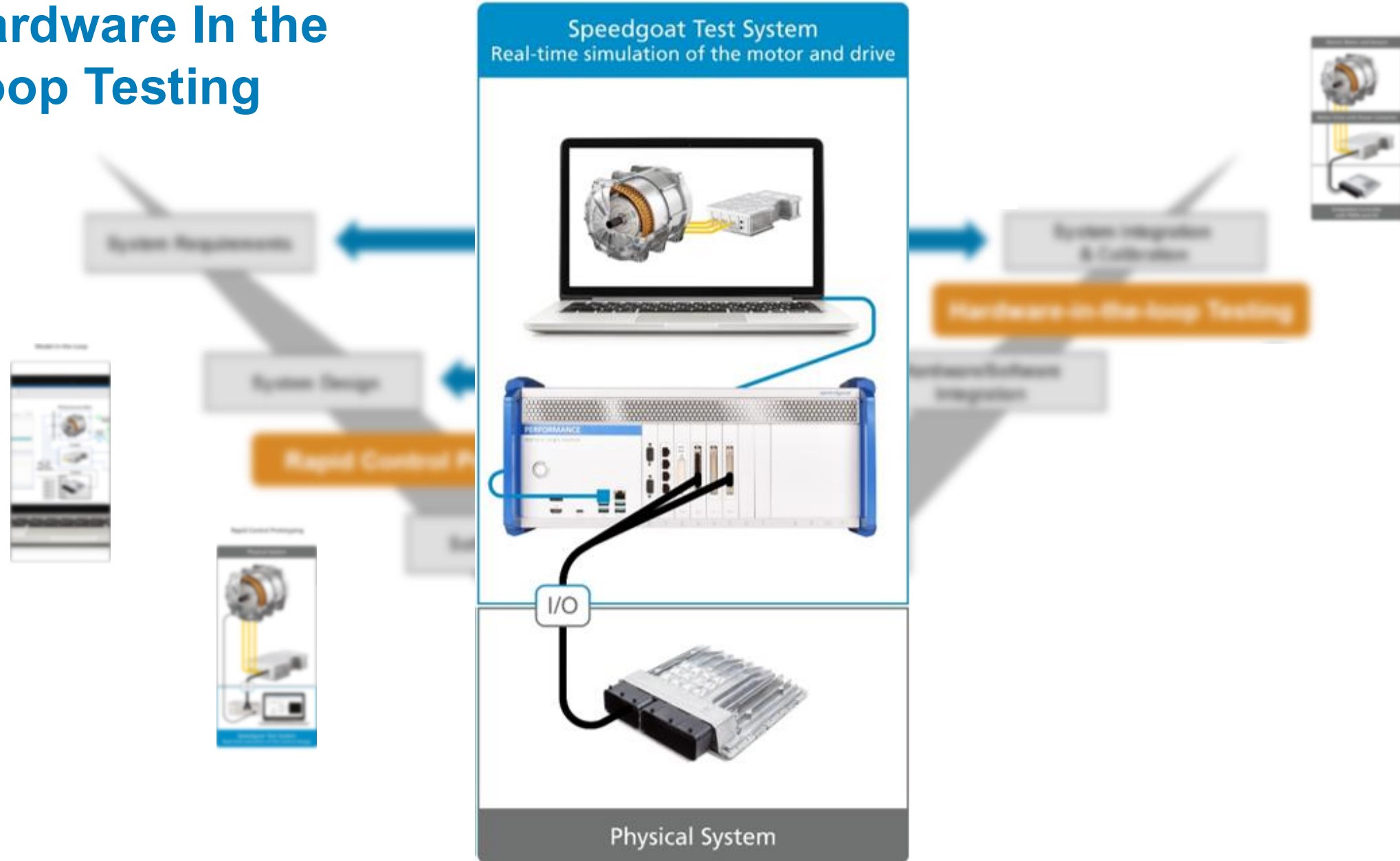

Setting Up a HIL Test Bench

- Using Simulink[®] and Simscape[™] for Controller Hardware in the Loop testing

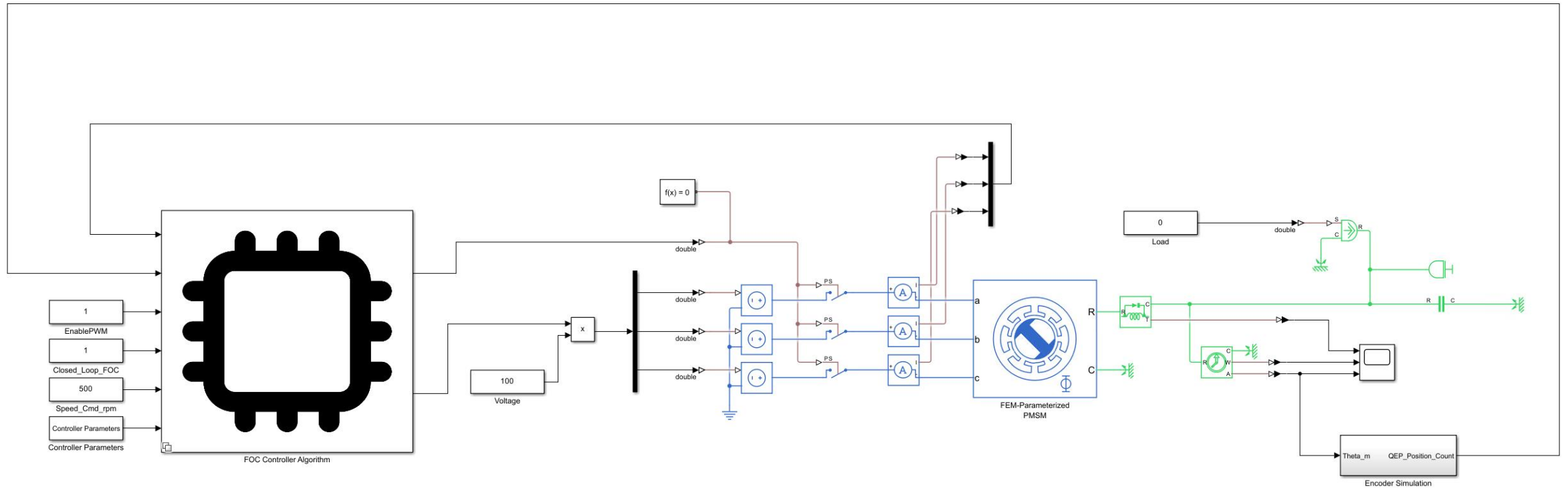

Setting Up a HIL Test Bench

- Using Simulink[®] and Simscape[™] for Controller Hardware in the Loop testing

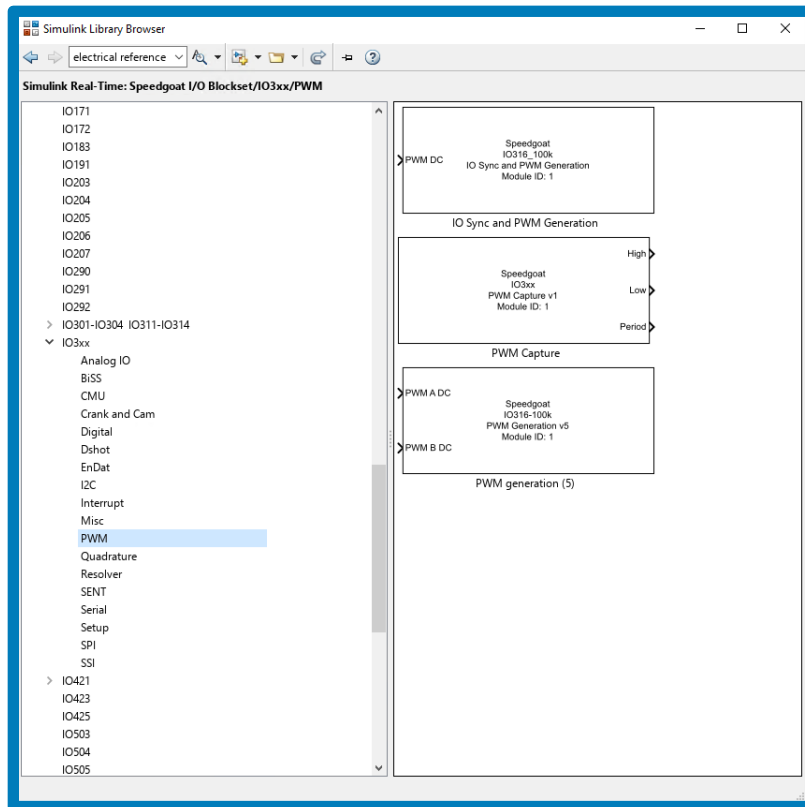

Setting Up a HIL Test Bench

- Using Simulink[®] and Simscape[™] for Controller Hardware in the Loop testing

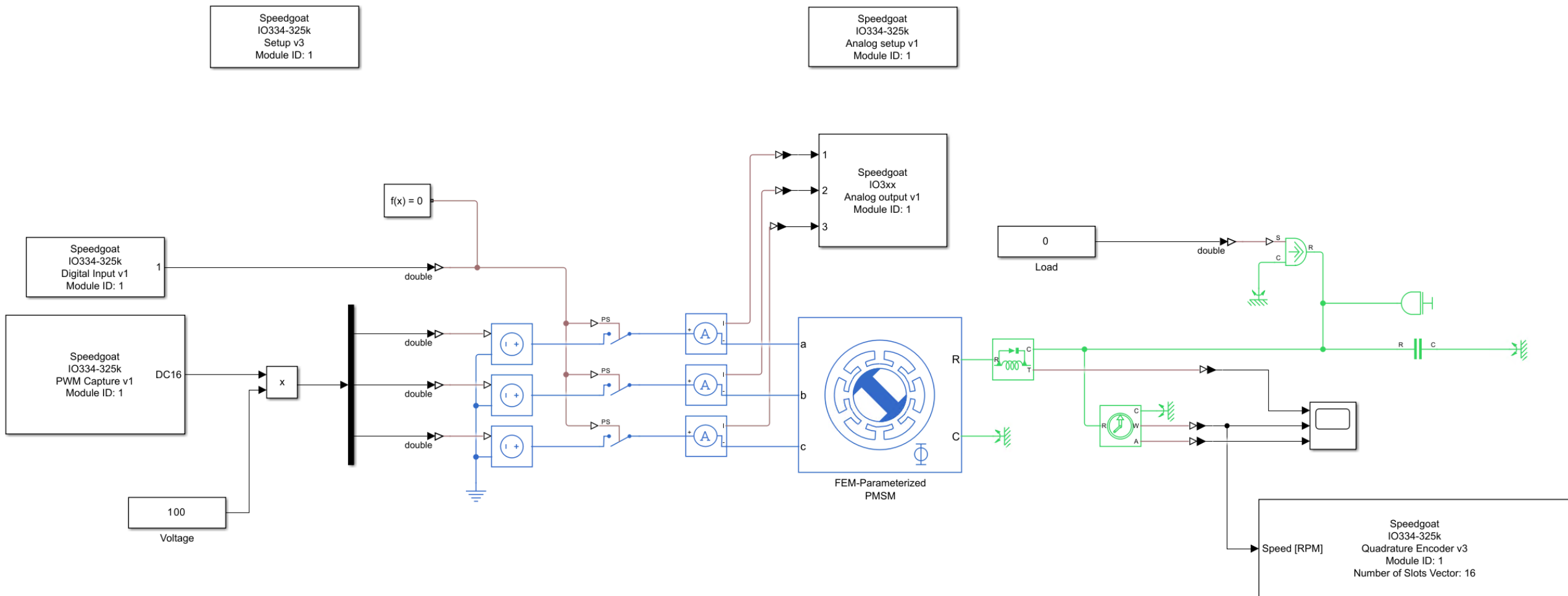

Setting Up a HIL Test Bench

- Using Simulink[®] and Simscape[™] for Controller Hardware in the Loop testing

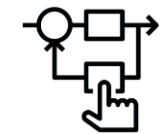
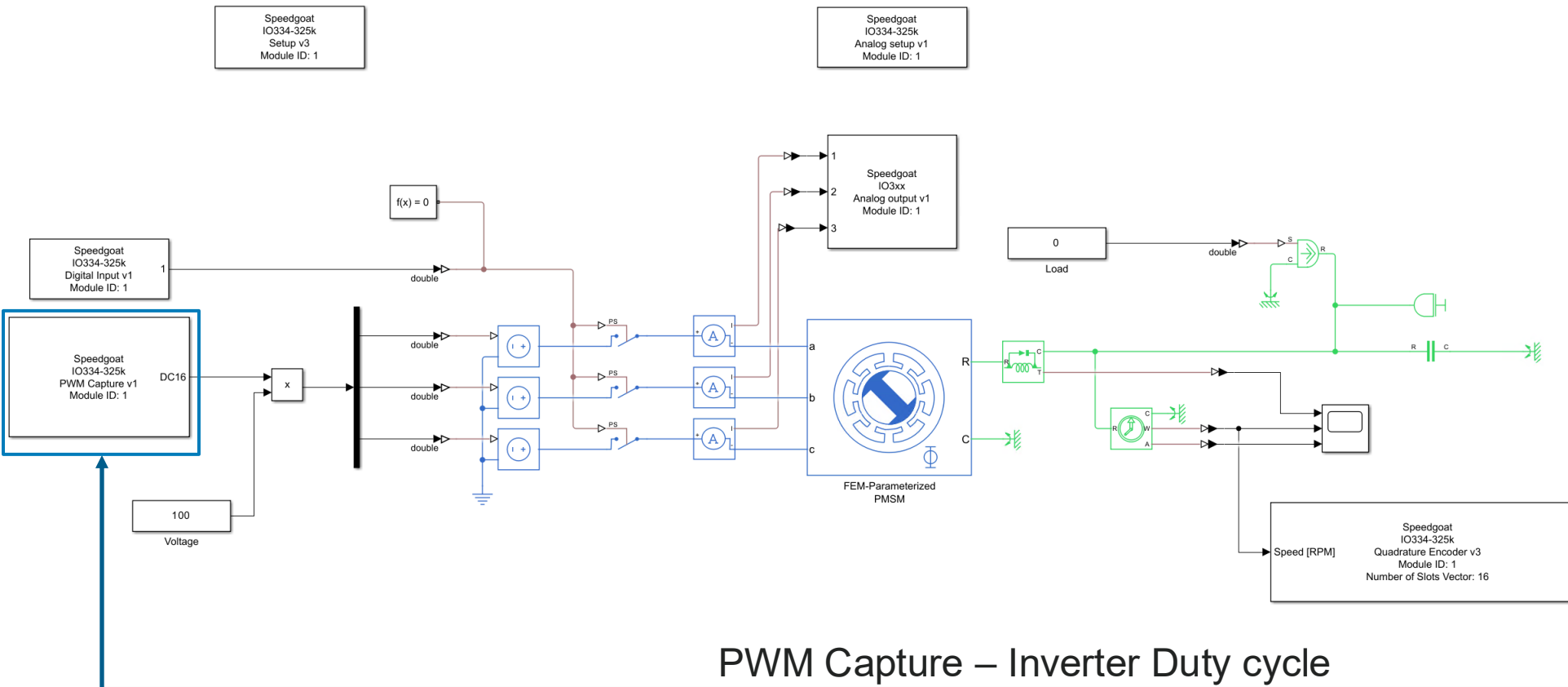

**Motor
Controller**

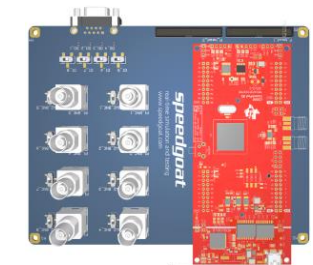

Setting Up a HIL Test Bench

- Using Simulink[®] and Simscape[™] for Controller Hardware in the Loop testing

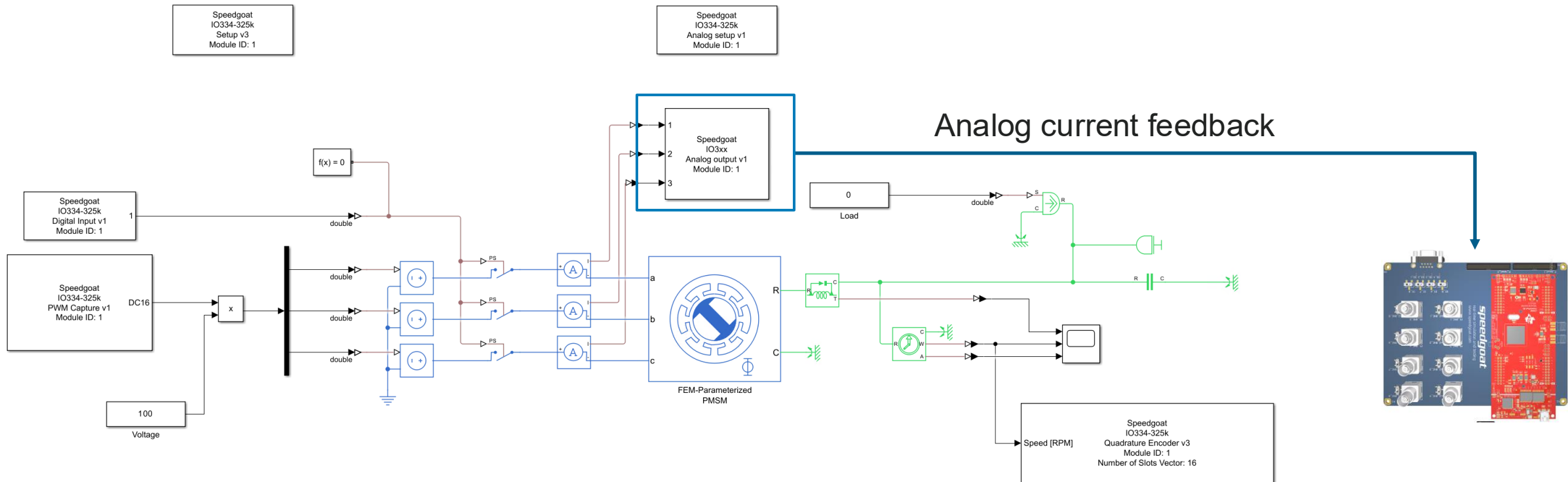

Setting Up a HIL Test Bench

- Using Simulink[®] and Simscape[™] for Controller Hardware in the Loop testing

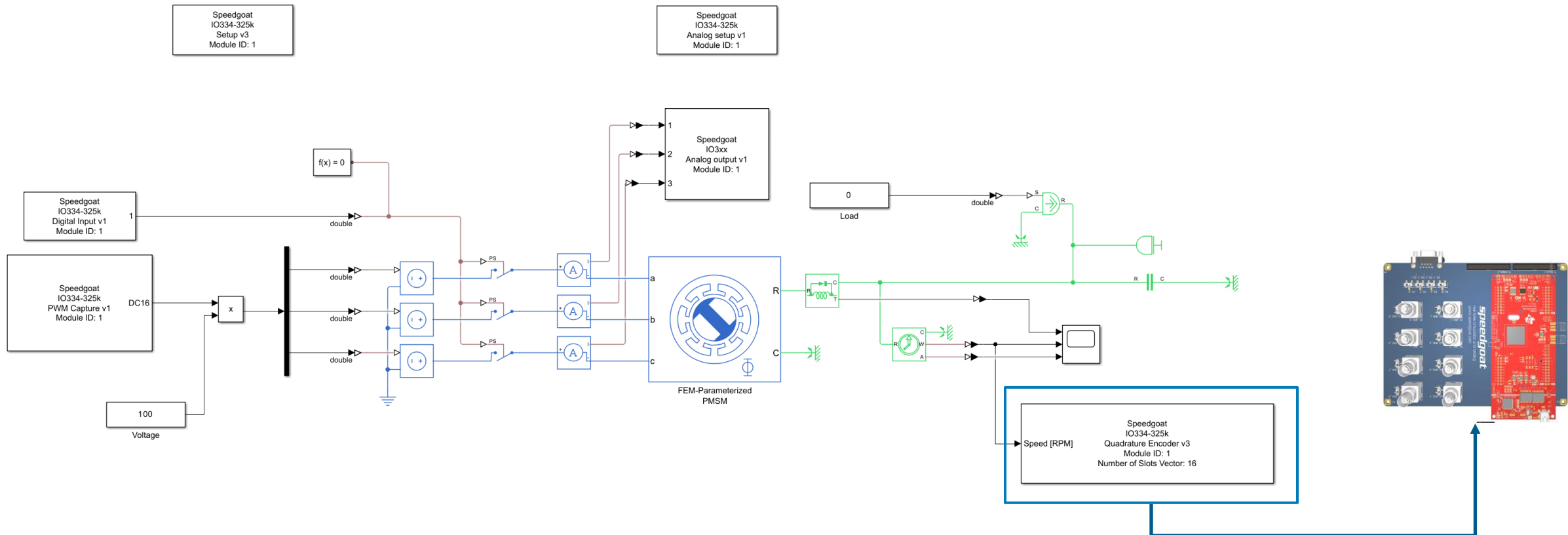

Setting Up a HIL Test Bench

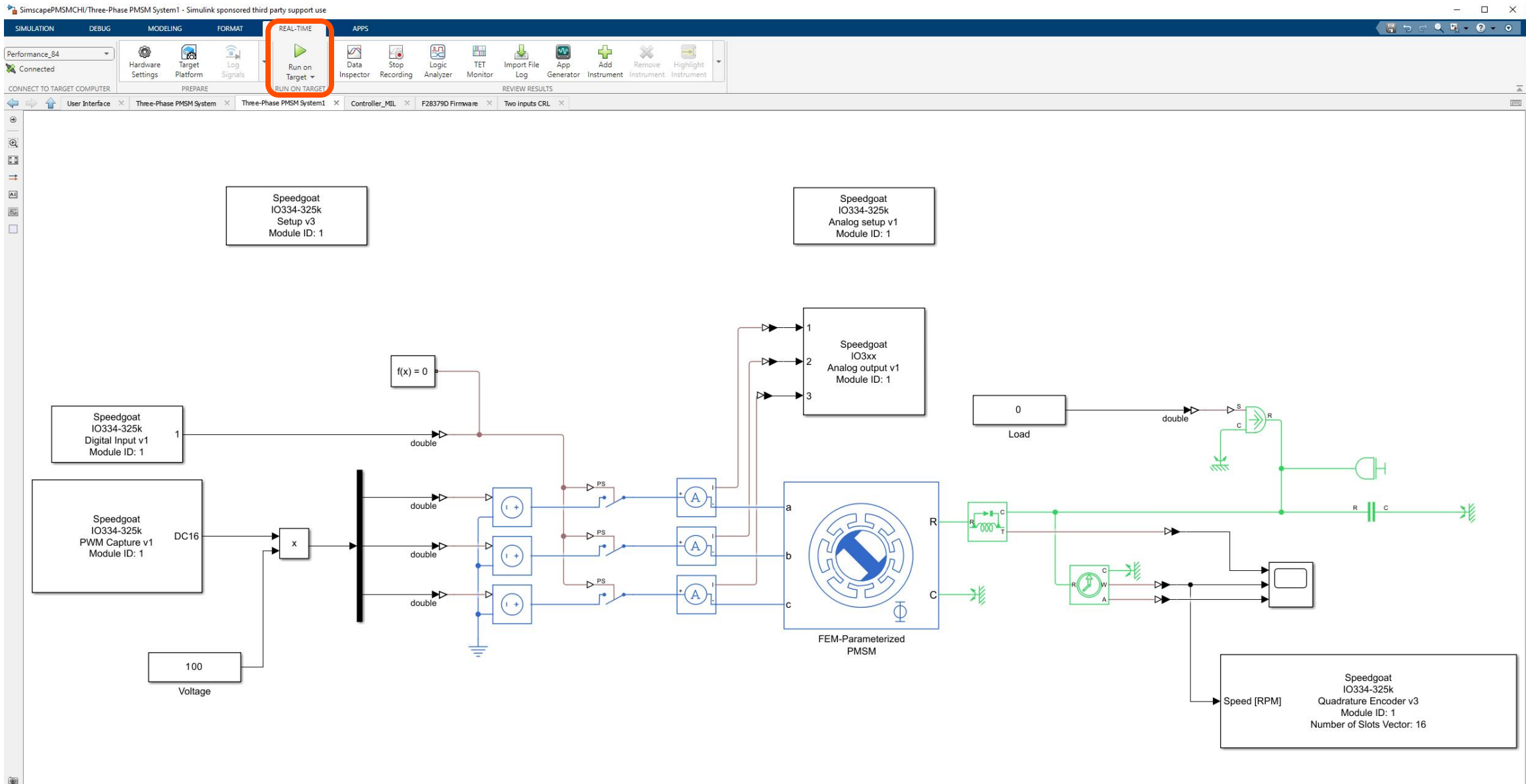

Setting Up a HIL Test Bench

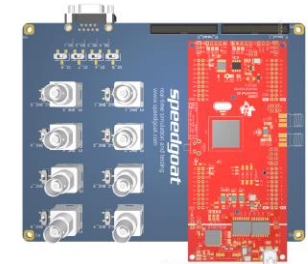
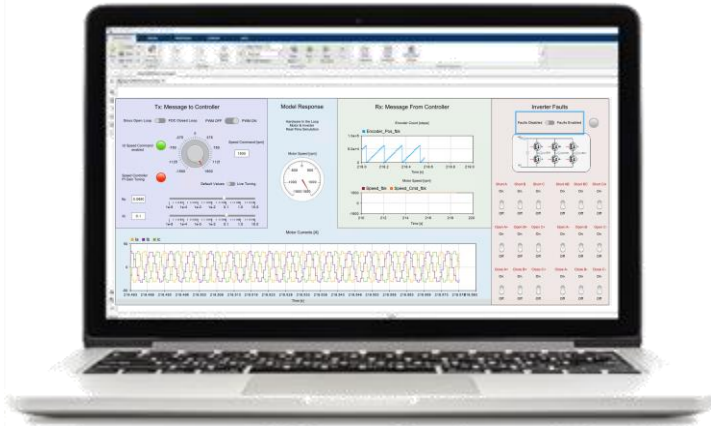
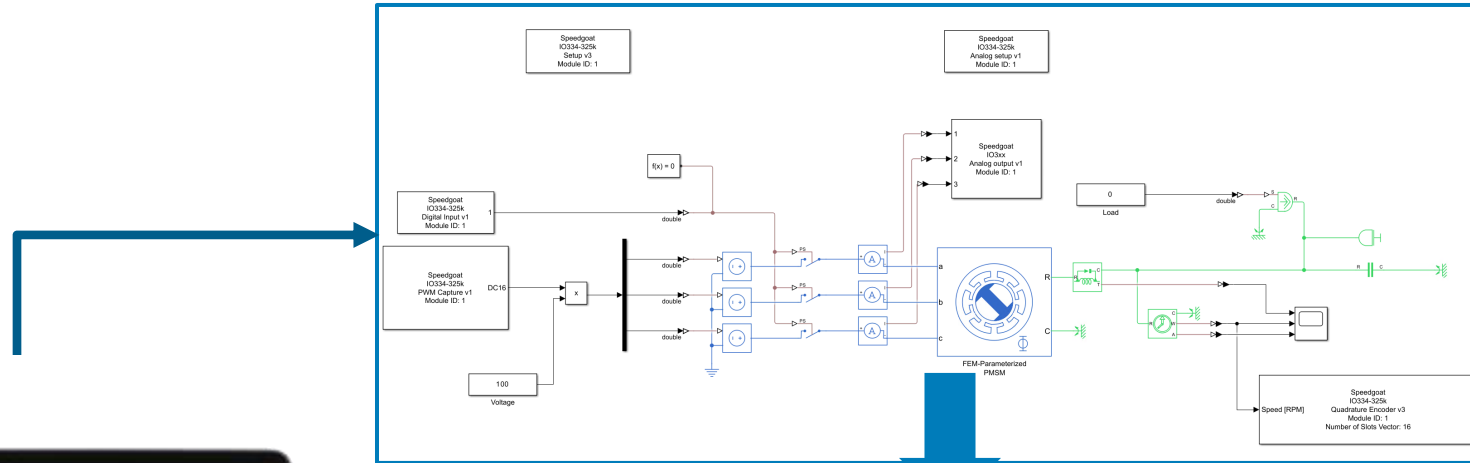

Setting Up a HIL Test Bench

**Development
Computer**

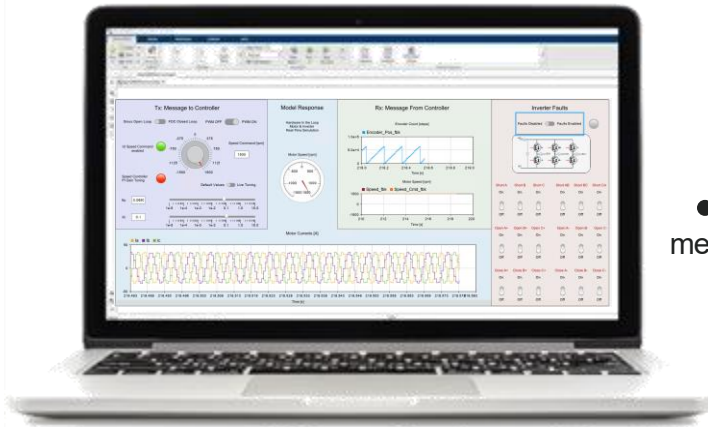

Test and
measurement data

**Speedgoat Motor Controller
HIL Test System**

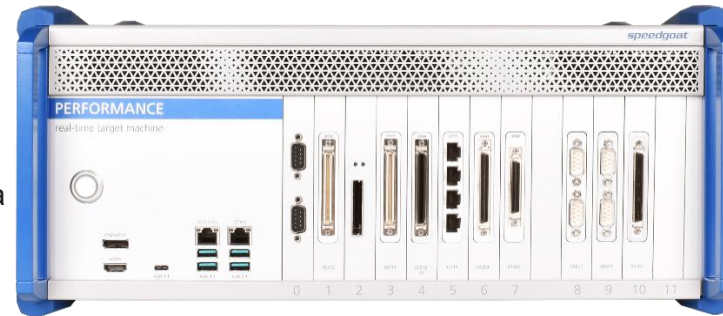

I/O

**Motor
Controller**

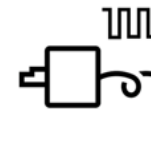
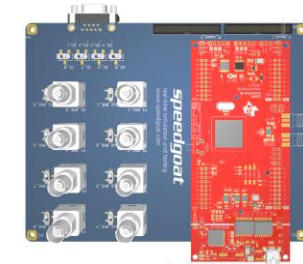

Setting Up a HIL Test Bench

Development Computer

Motor Controller

HIL Test System

Oscilloscope



Controller HIL Testing Lumped-Parameter Model with Average Inverter

- Torque and inductances independent of current and angle
- Current proportional to duty cycle
 - Controller imperfections (e.g. hardware noise)

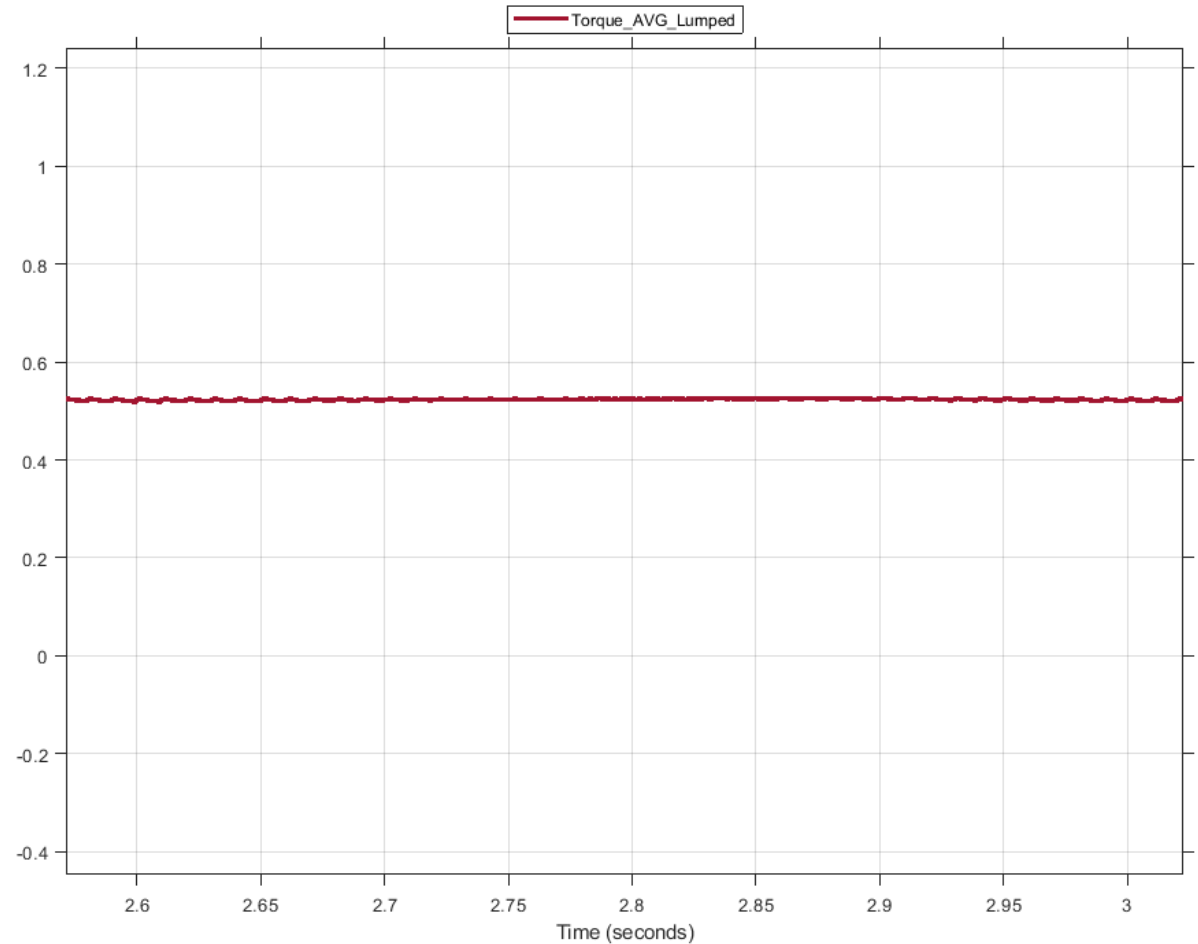
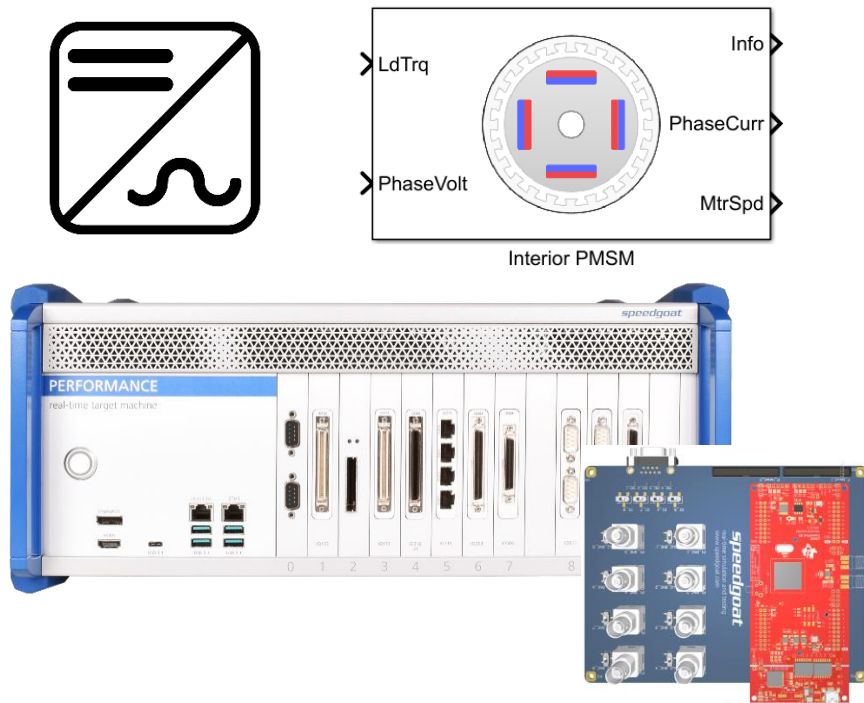

Controller HIL Testing

Import JMAG-RT® Data for Average Inverter Models

JMAG

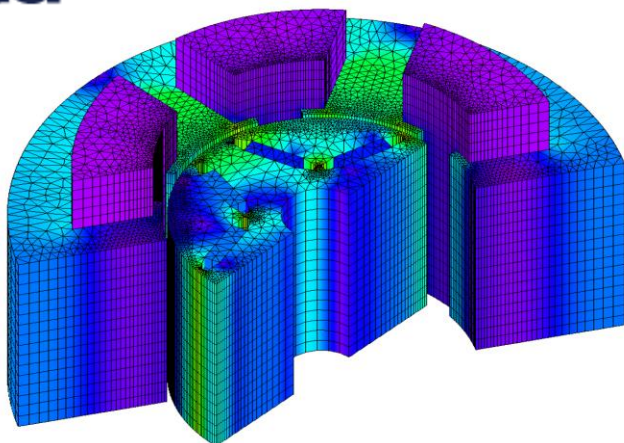

JMAG-RT®

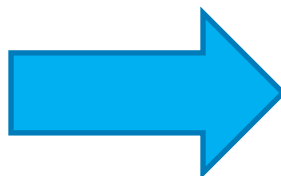

 **JMAG-Express Online**

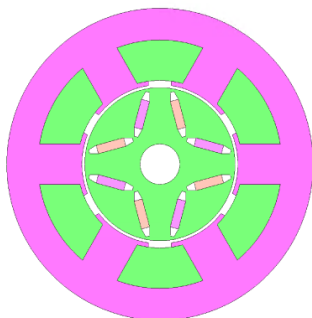

FEM motor generator

speedgoat
real-time simulation and testing

1k_S_C_IV.rtt

Import

Password Precision **Spatial harmonic**

Motor name Motor Type RTT version

Target Workflow

SLRT Model In the Loop Speedgoat FPGA **IO336**

LUT Extrapolation method **Linear**

Log

Controller HIL Testing

Import JMAG-RT® Data for Average Inverter Models

JMAG®

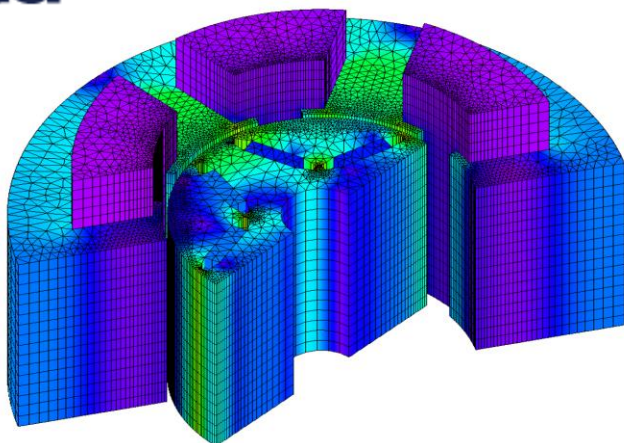

JMAG-RT®

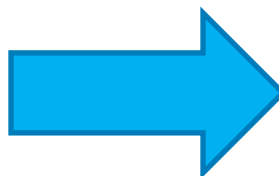

JMAG-Express Online

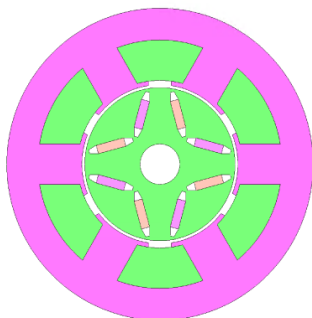

FEM motor generator

speedgoat
real-time simulation and testing

1k_S_C_IV.rtt

Import

Password Precision: Spatial harmonic

Motor name: 1k_S_C_IV Motor Type: PMSM 3-Phase RTT version: 24.11

Target Workflow

SLRT Model In the Loop Speedgoat FPGA IO336 Select a target template

Advanced Options

LUT Extrapolation method: Linear

Log

.rtt file imported successfully!

Controller HIL Testing

Import JMAG-RT® Data for Average Inverter Models

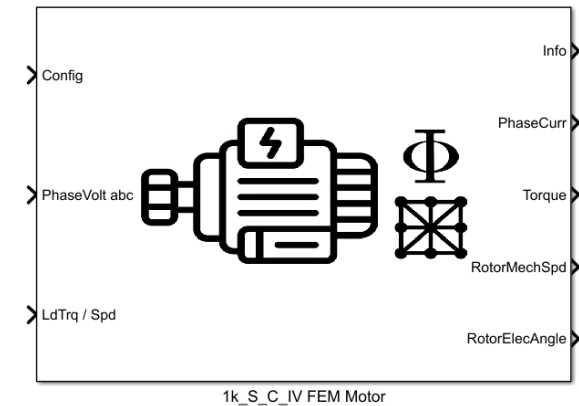
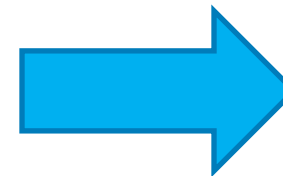
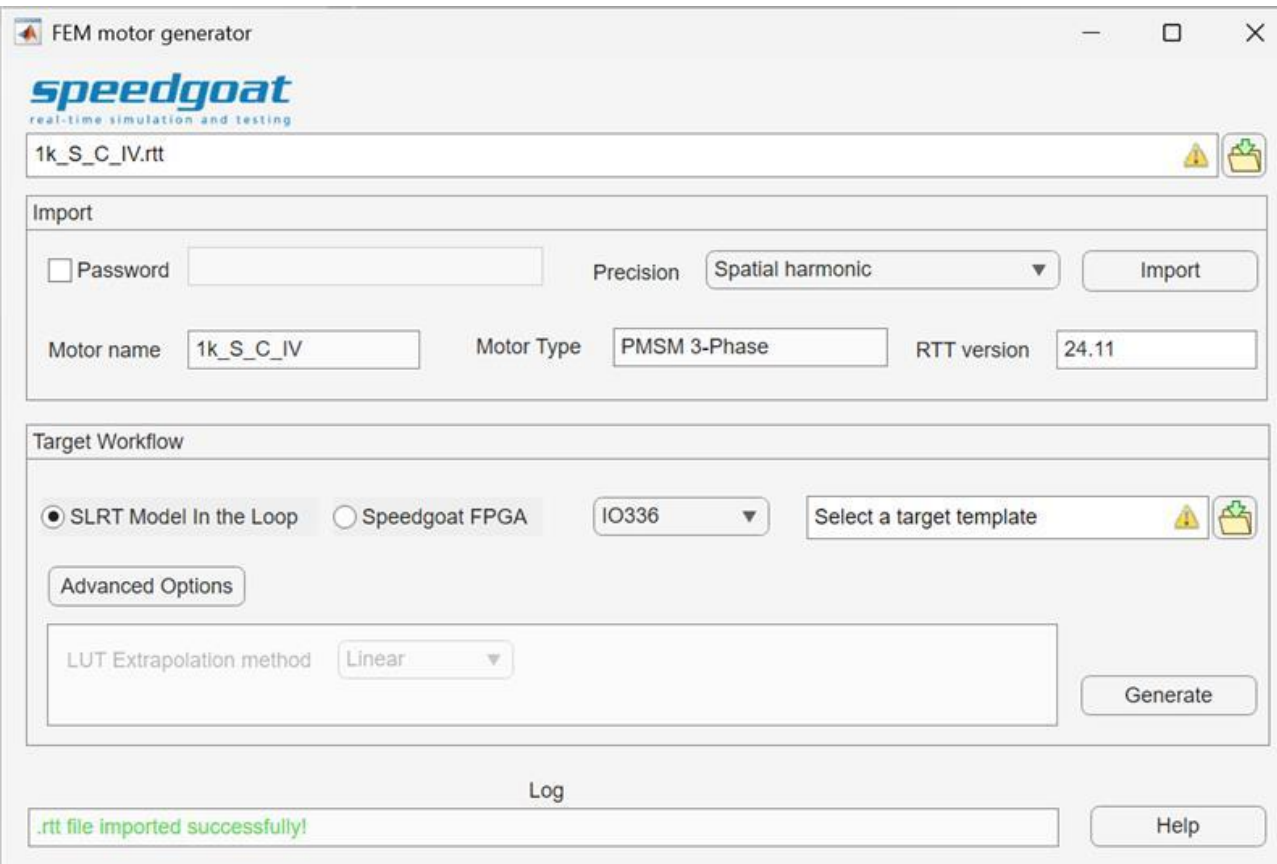

Controller HIL Testing Speedgoat FEM Model and Average Inverter

- Saturation
 - Torque and flux depend on current
- Spatial harmonics
 - Torque and flux depend on current

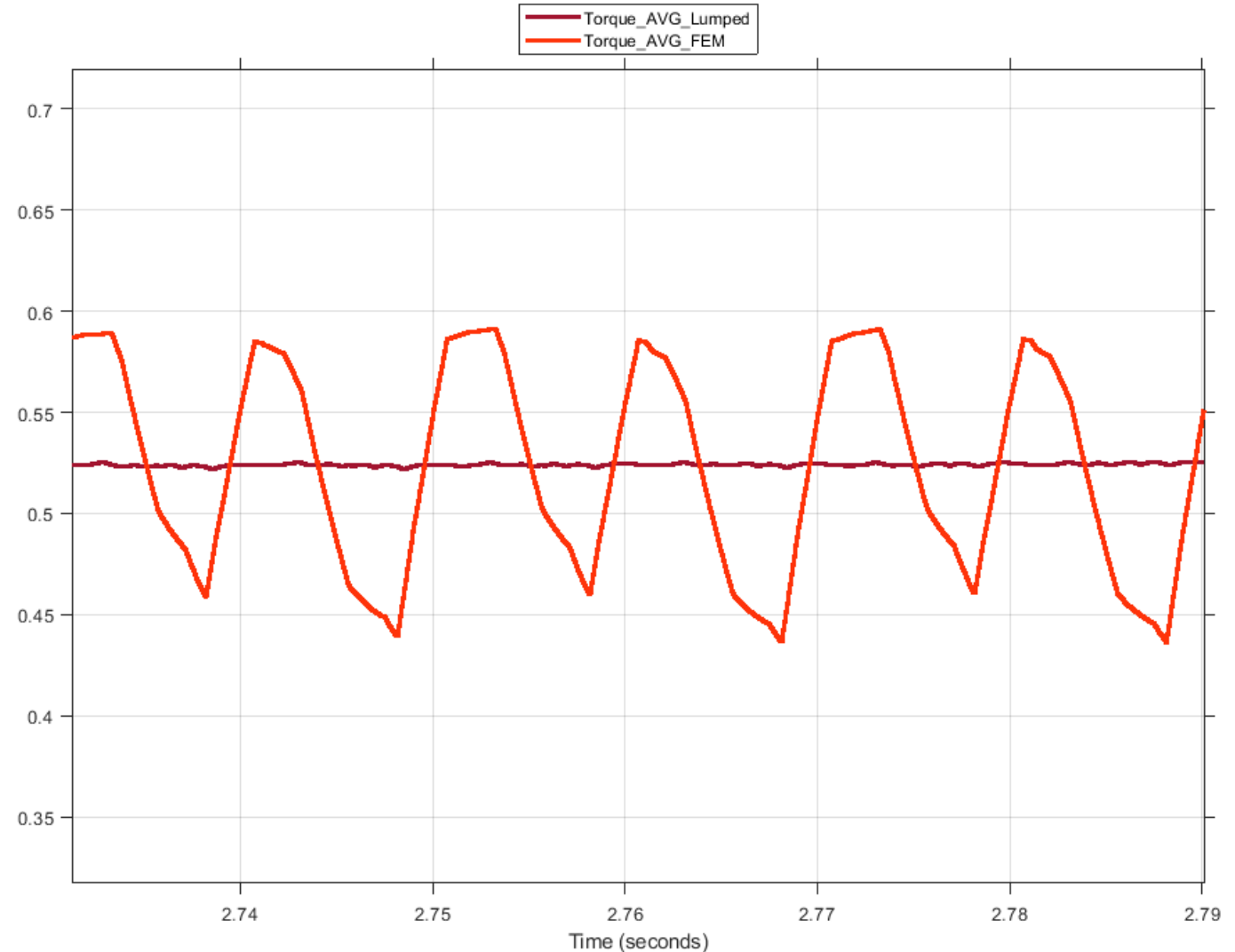
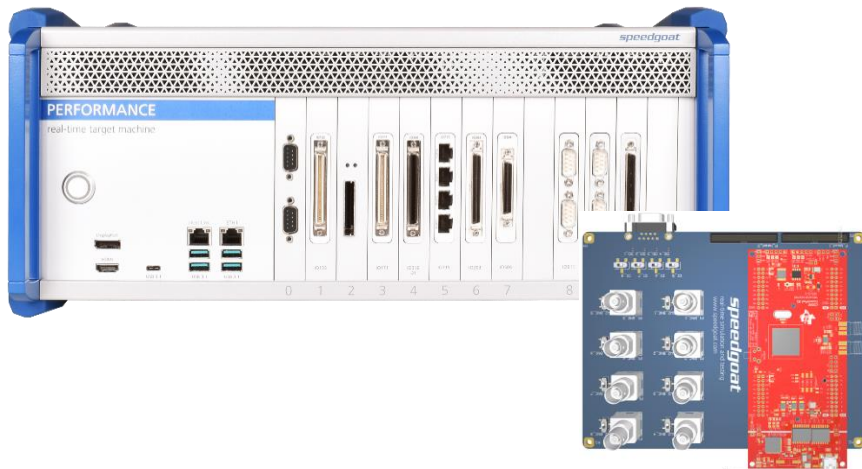
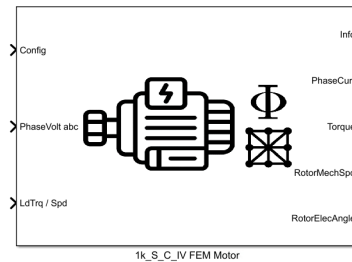

Controller HIL Testing Inverter HIL Simulation

Solution overview – A twofold solution for different requirements

CPU execution

- Multicore CPUs
- High-Speed I/O
- Automatic C code generation

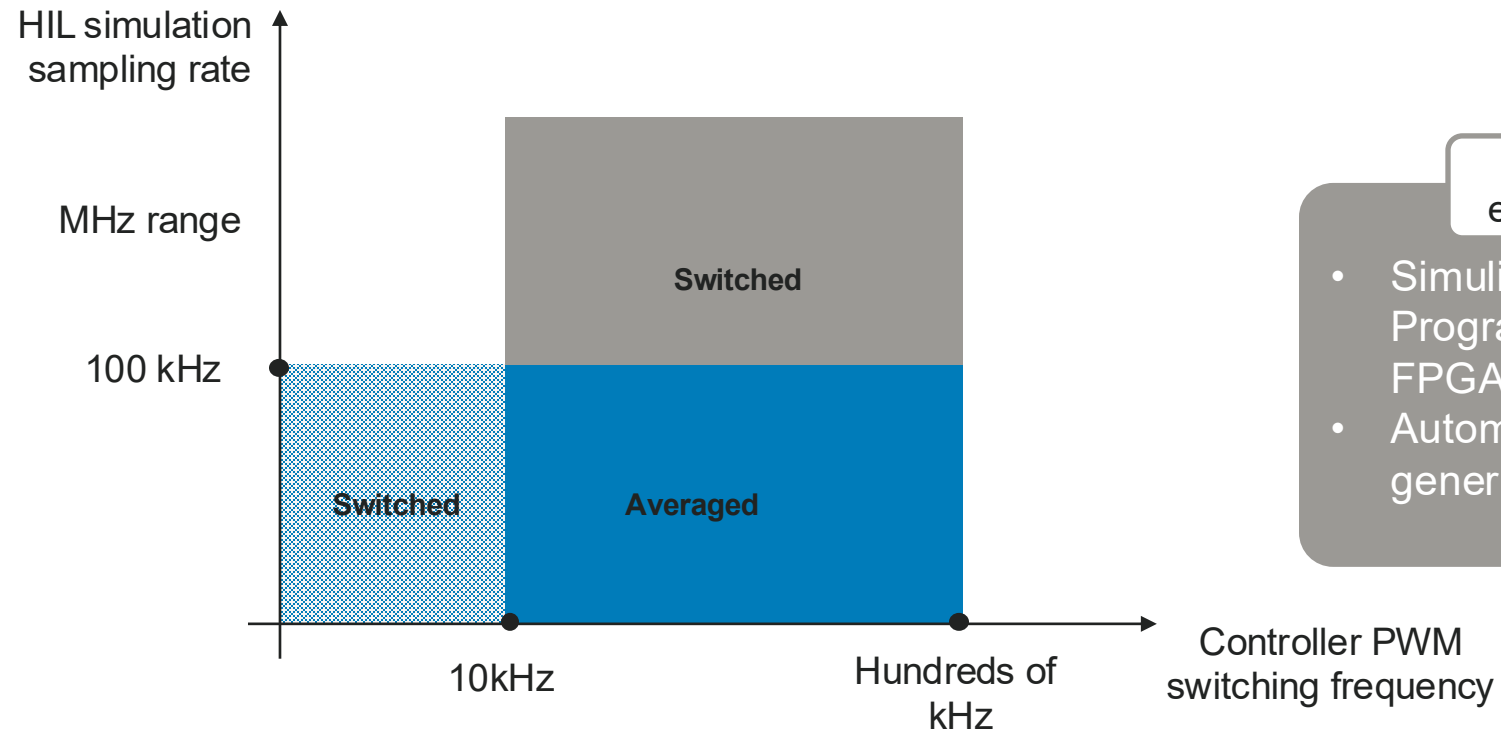

FPGA execution

- Simulink-Programmable FPGAs
- Automatic HDL code generation

Controller HIL Testing Lumped-Parameter PMSM and Switching Inverter

- Lumped-parameter PMSM
- Switching inverter
 - Speedgoat FPGA-ready templates
 - Simscape™ to HDL

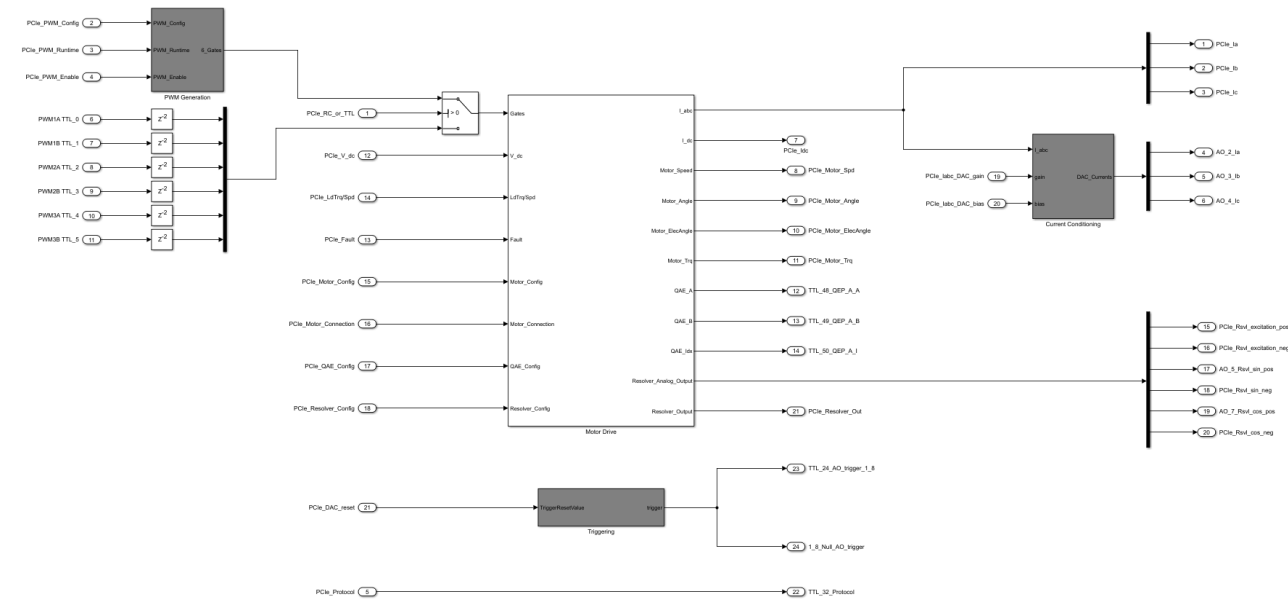
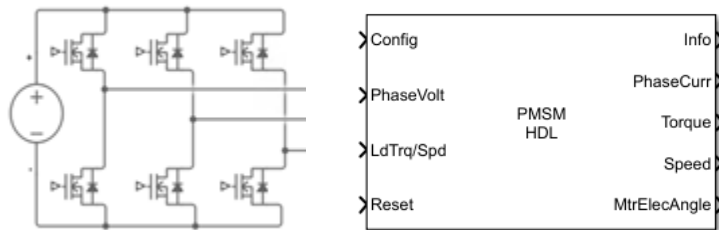

Controller HIL Testing Lumped-Parameter PMSM and Switching Inverter

- Lumped-parameter PMSM
- Switching inverter
 - Speedgoat FPGA-ready templates
 - Simscape™ to HDL

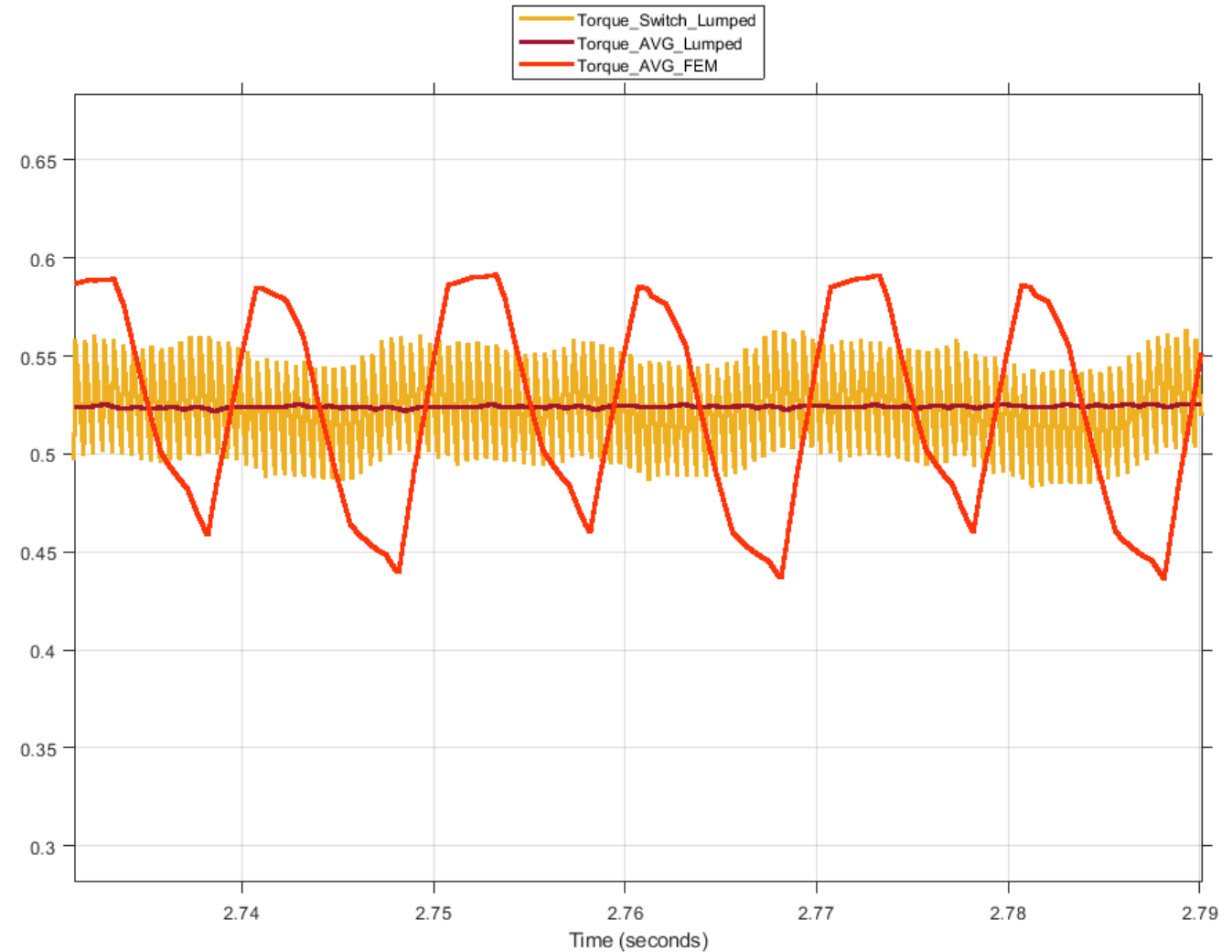
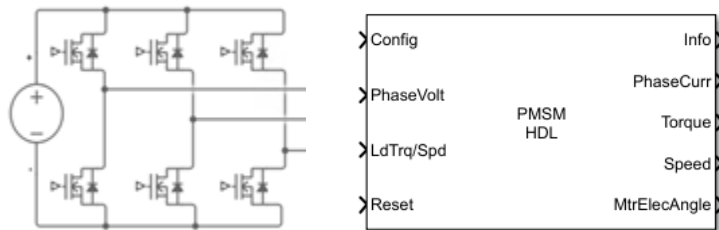

Controller HIL Testing Lumped-Parameter PMSM and Switching Inverter

- Reduce current ripples
 - Adjust PWM frequency
 - Tune the impedances
 - Adapt the controller
- Avoid resonances

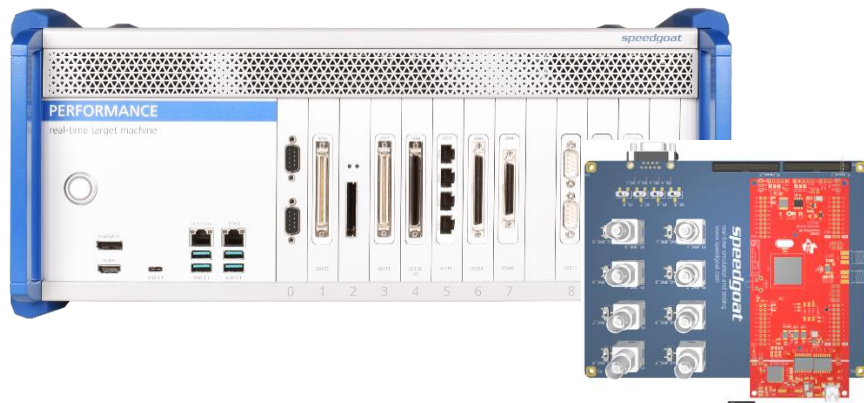
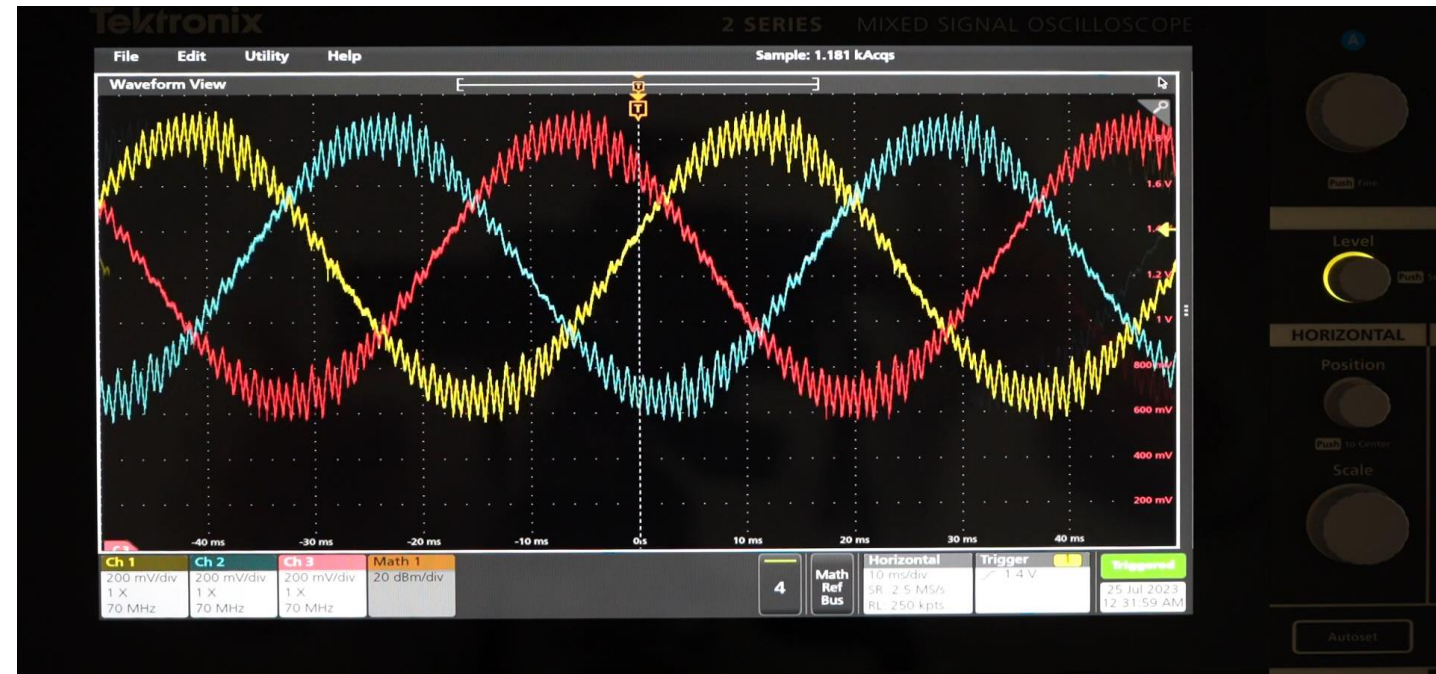
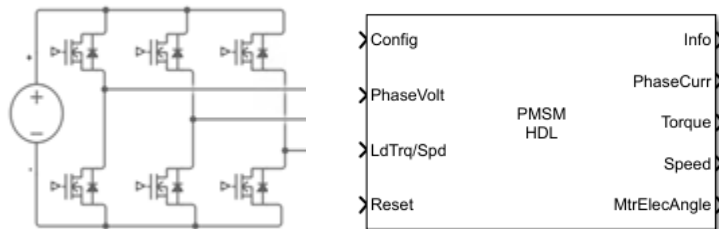

Controller HIL Testing

Combine JMAG-RT[®] Data with Switching Inverters on FPGA

JMAG[®]

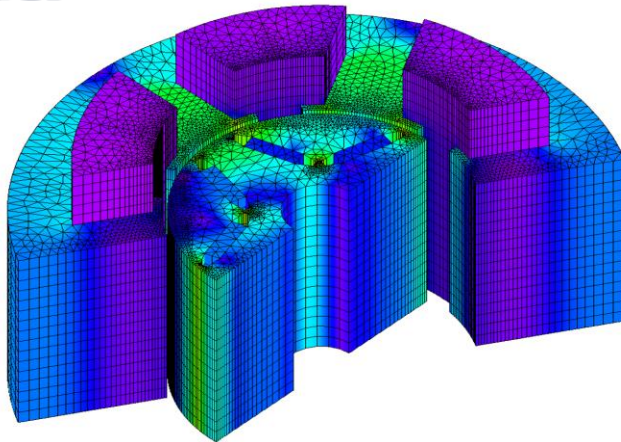

JMAG-RT[®]

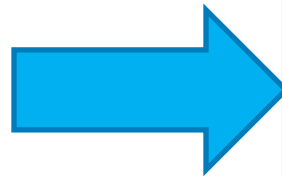

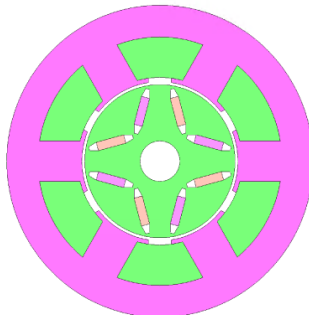

 **JMAG-Express Online**



FEM motor generator

speedgoat
real-time simulation and testing

Select source file  

Import

Password Precision **Spatial harmonic**

Motor name Motor Type RTT Version

Target Workflow

SLRT Model In the Loop Speedgoat FPGA

LUT Extrapolation method **Linear**

Log

Controller HIL Testing

Combine JMAG-RT[®] Data with Switching Inverters on FPGA

JMAG[®]

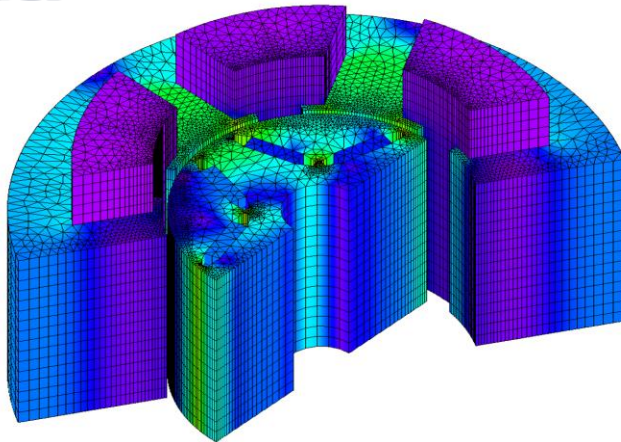

JMAG-RT[®]

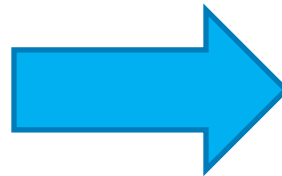

 **JMAG-Express Online**

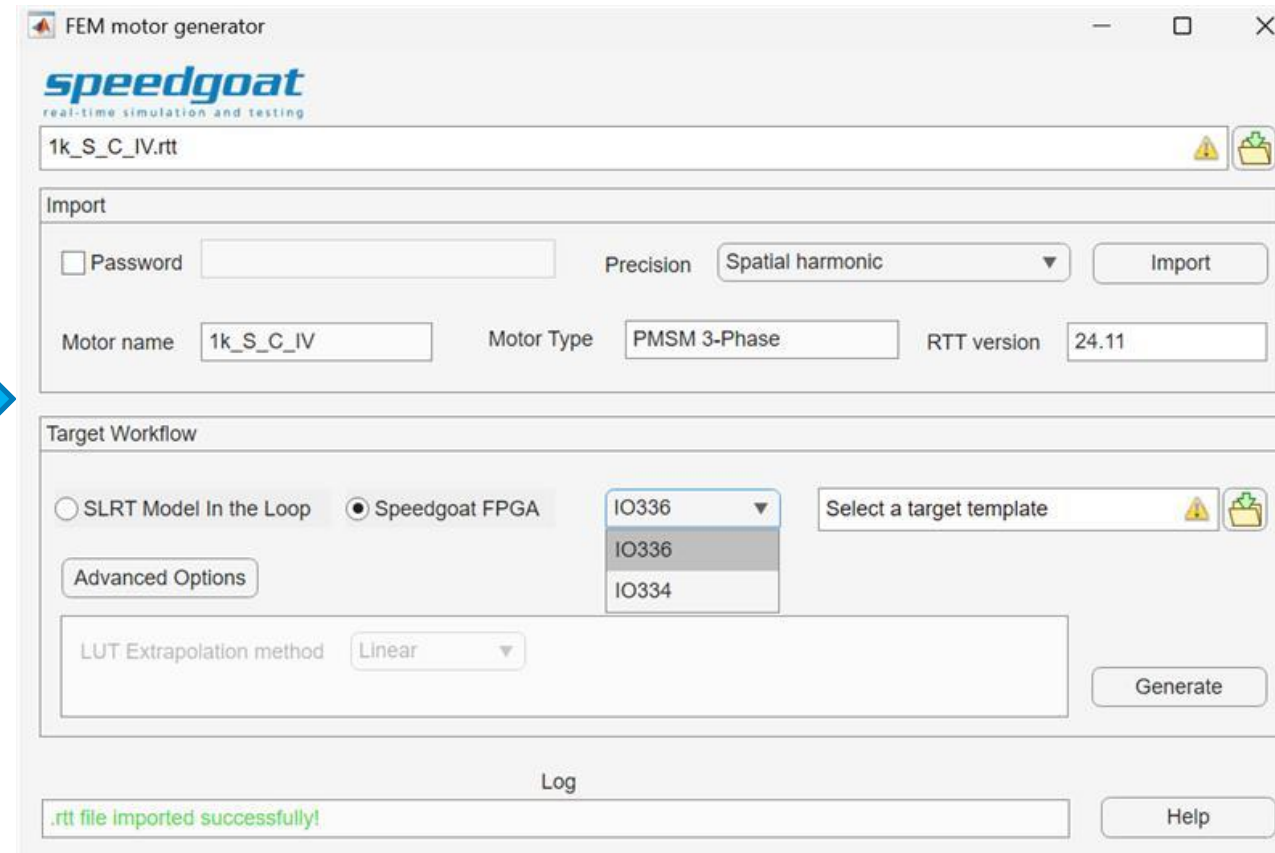
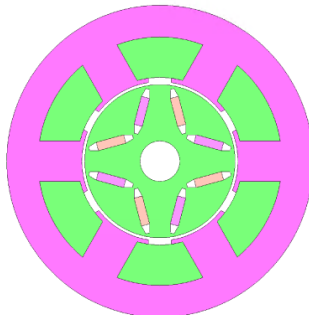

The screenshot shows the 'FEM motor generator' window in the Speedgoat software. The window title is 'FEM motor generator' and it features the Speedgoat logo. The main area displays the file name '1k_S_C_IV.rtt'. Below this, there are several configuration sections:

- Import:** Includes a 'Password' field, a 'Precision' dropdown set to 'Spatial harmonic', and an 'Import' button.
- Motor Parameters:** Shows 'Motor name' as '1k_S_C_IV', 'Motor Type' as 'PMSM 3-Phase', and 'RTT version' as '24.11'.
- Target Workflow:** Features two radio buttons: 'SLRT Model In the Loop' (unselected) and 'Speedgoat FPGA' (selected). A dropdown menu is open, showing 'IO336' as the selected option, with 'IO336' and 'IO334' as other visible options. To the right is a 'Select a target template' field with a warning icon and a folder icon.
- Advanced Options:** Includes a 'LUT Extrapolation method' dropdown set to 'Linear' and a 'Generate' button.
- Log:** A status bar at the bottom shows the message '.rtt file imported successfully!'.
- Help:** A 'Help' button is located in the bottom right corner.

Controller HIL Testing Combine JMAG-RT® Data with Switching Inverters on FPGA

- FEM PMSM with JMAG® Data
 - Motor torque ripple contributions
- Switching Inverter
 - Current ripple contributions

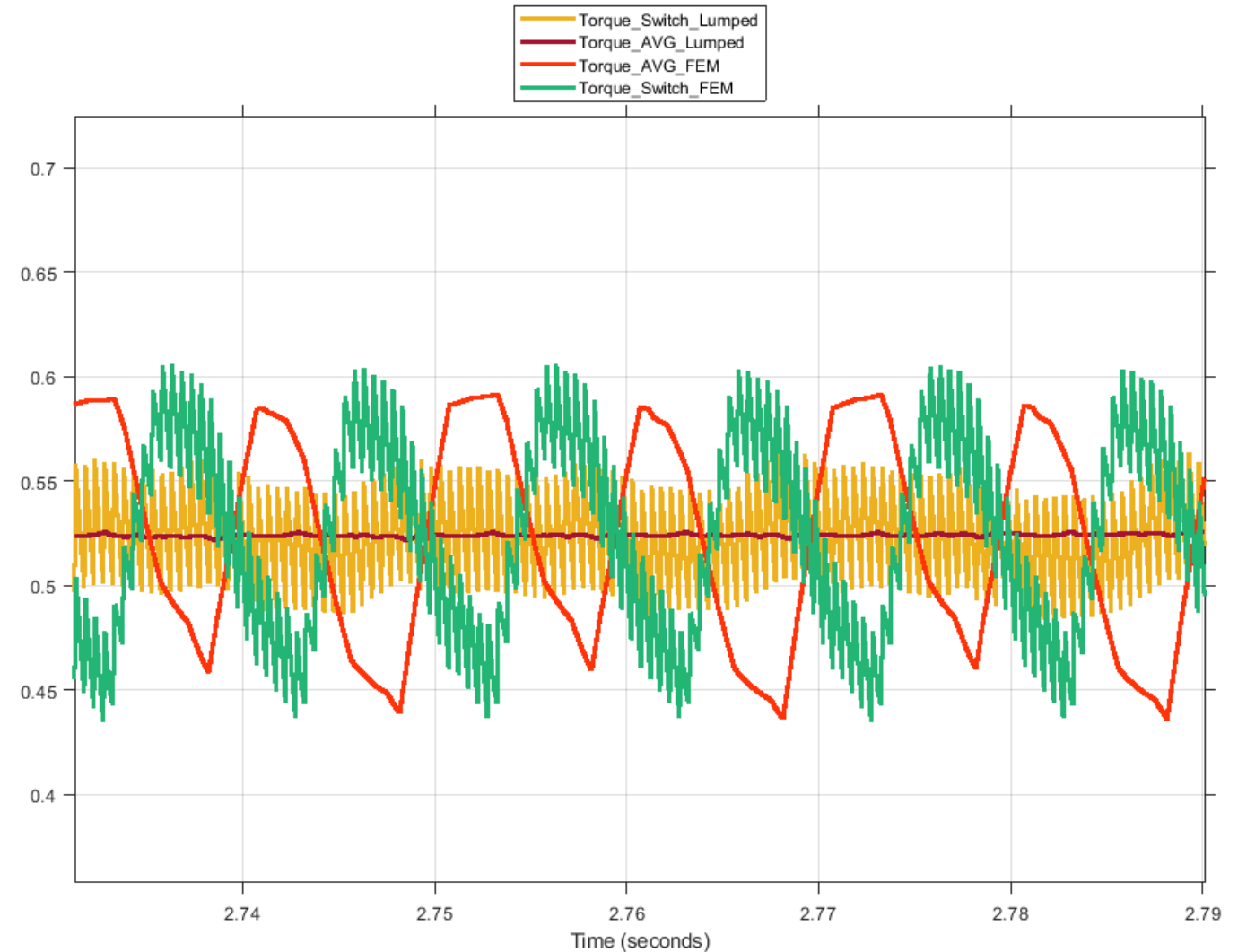
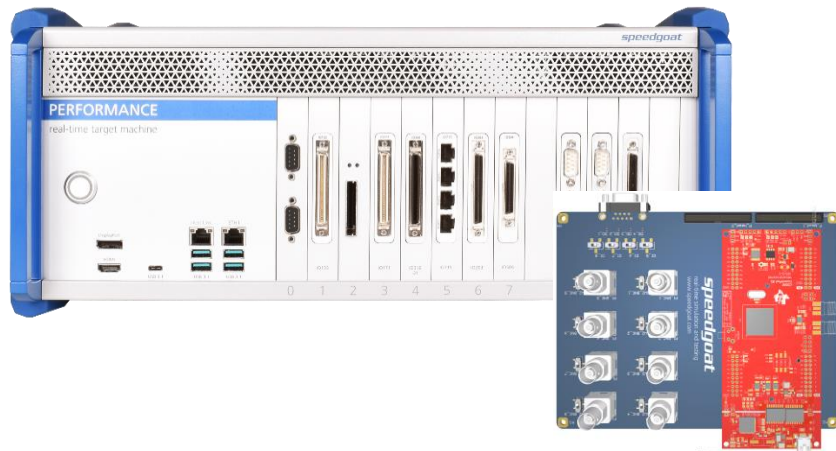
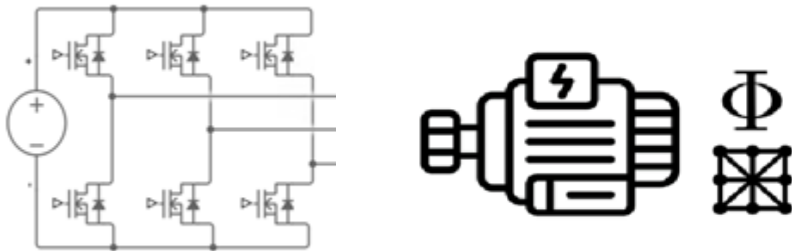

Controller HIL Testing Combine JMAG-RT® Data with Switching Inverters on FPGA

- FEM PMSM with JMAG® Data
 - Motor torque ripple contributions
- Switching Inverter
 - Current ripple contributions

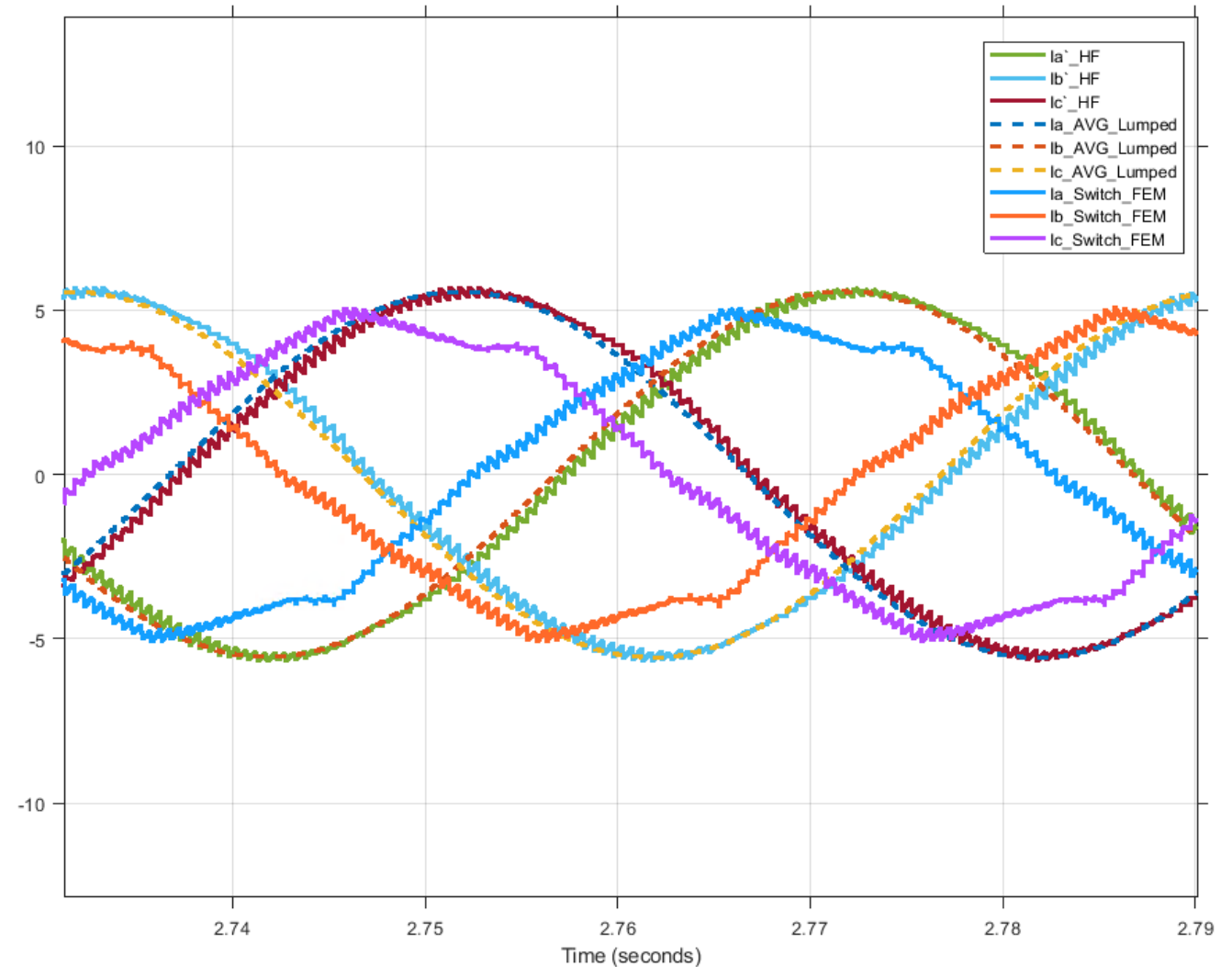
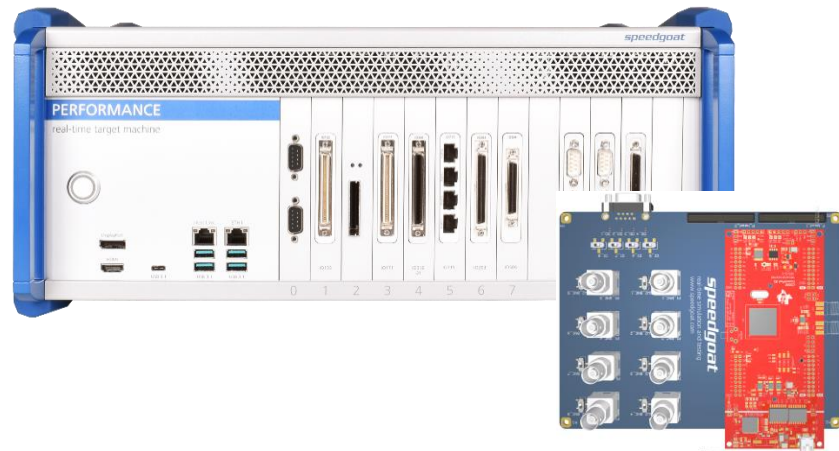
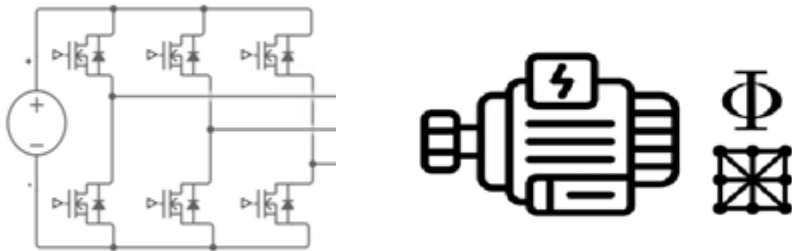

Controller HIL Testing Manage and Automate Testing

- Simulink® Test Manager
 - Autor test cases
 - Store results
 - Link to requirements
 - Applicable to all development stages

The screenshot displays the Simulink Test Manager interface. The top menu bar includes options like New, Open, Save, Cut, Copy, Delete, Test Spec Report, Run, Run with Stepper, Stop, Parallel, Report, Visualize, Highlight in Model, Export, Model Testing Dashboard, Preferences, and Help. The main workspace is divided into a Test Browser on the left and a configuration panel on the right.

Test Browser: Shows a tree view of test cases under 'TestCases'. The selected test is 'Speed_Step_500rpm_FOC' under the 'Baseline_CAN_HIL_Tests' folder. Other tests include 'Speed_Step_500rpm_Sinus_Fault', 'Real_Time_MIL', 'RT_MIL_500rpm_SINUS', 'RT_MIL_500rpm_FOC', 'MIL', 'MIL_500rpm_SINUS', and 'MIL_500rpm_FOC'.

Configuration Panel: Shows settings for the selected test. The 'SYSTEM UNDER TEST*' section includes 'Load Application From' (Model), 'Model' (FEAPMSMCHILsystem), and 'Target Computer' ([Default]). The 'TEST HARNESS*' section shows 'Harness' (PMSM3P2LinverterCHILsystem_Harness1). Below are sections for 'SIMULATION SETTINGS OVERRIDES*', 'PARAMETER OVERRIDES', 'CALLBACKS*', 'INPUTS', 'SIMULATION OUTPUTS', and 'BASELINE CRITERIA*'. A checkbox 'Include baseline data in test result' is present. A table at the bottom shows baseline criteria for 'SpeedStep500rpm....' with values for ABS TOL, REL TOL, LEADING TOL, and LAGGING TOL.

SIGNAL NAME	ABS TOL	REL TOL	LEADING TOL	LAGGING TOL
SpeedStep500rpm....	0	0.00%	0	0

Controller HIL Testing Manage and Automate Testing

- Simulink Test Manager
 - Author test cases
 - Store results
 - Link to requirements
 - For all development stages

- Convert simulation test cases to real-time tests

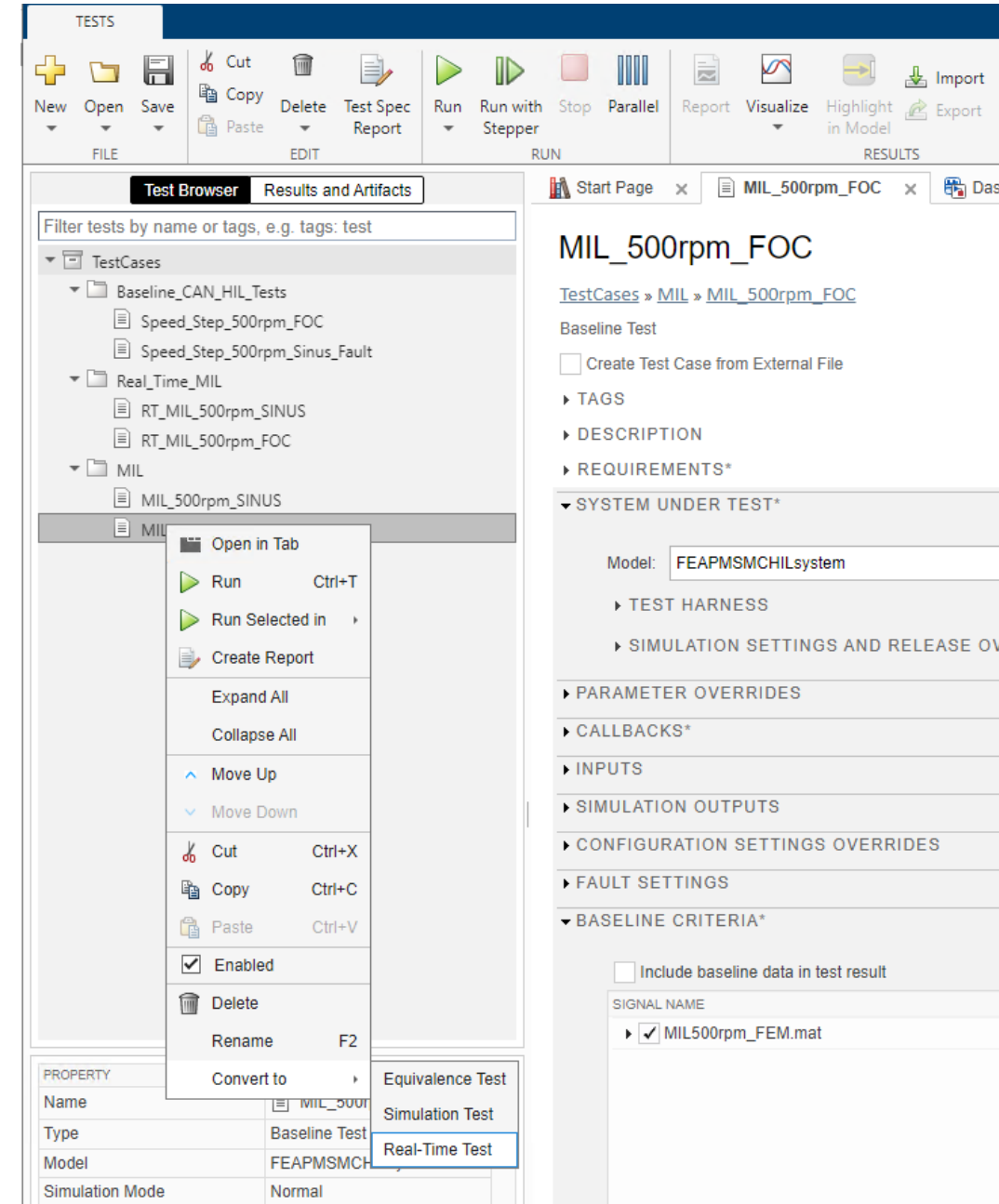

Controller HIL Testing Manage and Automate Testing

- Final HIL test verifies torque ripple requirements with all contributing components

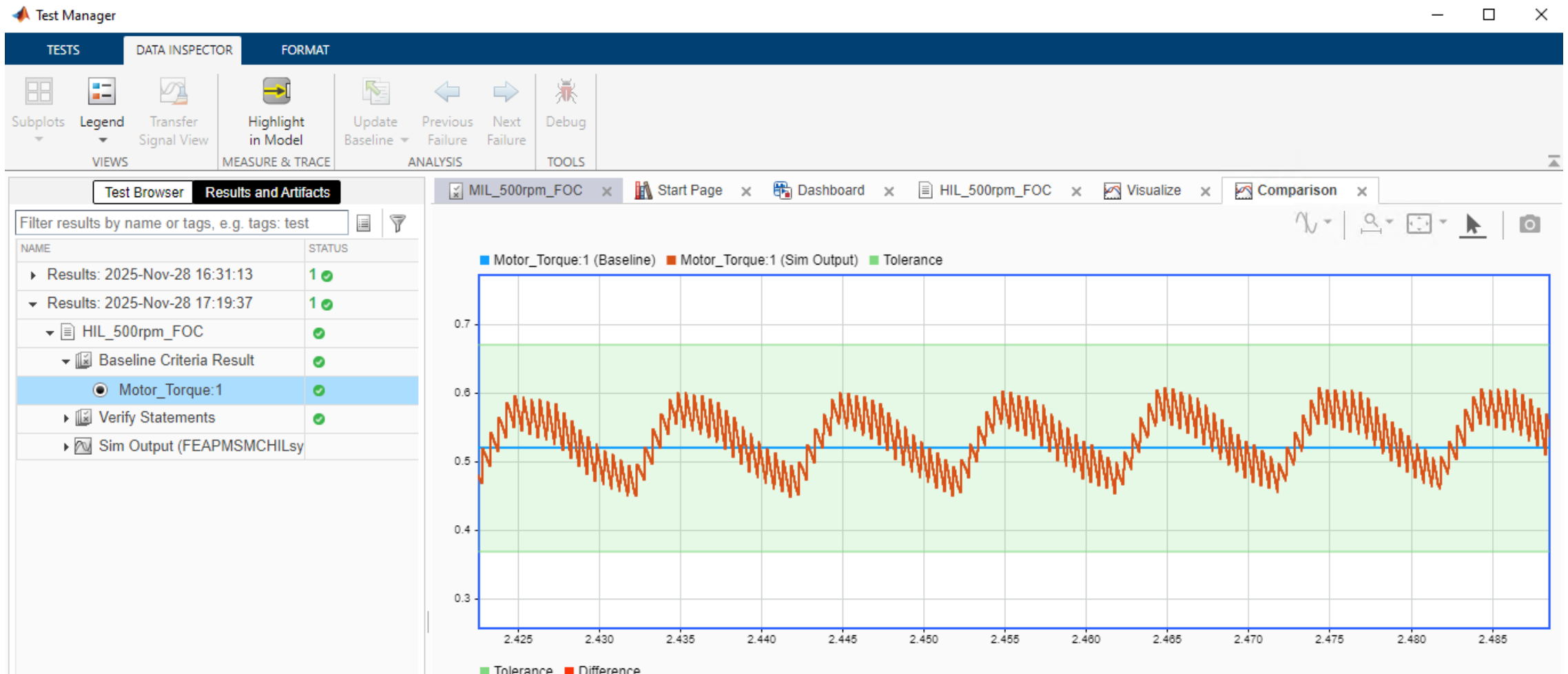

Controller HIL Testing

Manage and Automate Testing

- The requirement is verified automatically to enable full traceability

The screenshot shows the Requirements Editor interface. The main window displays a table of requirements under the 'Mot...' category. The table has columns for Index, ID, Summary, Verified, and Implemented. Requirement 5, '5. Max Torque Ripple', is highlighted. The 'Verified' column for this requirement shows a green bar, indicating it is verified. The 'Implemented' column shows a blue bar, indicating it is implemented.

Index	ID	Summary	Verified	Implemented
1	1. Min Top Speed	The motor drive shall reach at least 1000 rpm	Yellow bar	Blue bar
2	2. Min Speed and acceleration	The motor Drive Shall reach at lest 500 RPM in less than 5s	Yellow bar	Blue bar
3	3. Speed Stability	The speed shall always be within 10% of the command	Yellow bar	Blue bar
4	4. Min Torque	The Motor shall provide a minimum of 3Nm	Yellow bar	Blue bar
5	5. Max Torque Ripple	The torque ripple shall not exceed 0.3Nm at the nominal speed (rpm).	Green bar	Blue bar

The right-hand pane shows the 'Properties' for the selected requirement (Index: 5). The 'Summary' field contains the text: 'The torque ripple shall not exceed 0.3Nm at the nominal speed (rpm)'. The 'Description' field contains the text: 'In stable load and speed command conditions, the torque ripple at 500rpm shall not exceed 0.3Nm'. The 'Links' section shows 'Implemented by:' with links to 'FEM-3dDQ-Flux-Torque-PMSM' and 'Verified by:' with a link to 'HIL_500rpm_FOC' which has a green checkmark.

Automating HIL Testing for Continuous Integration

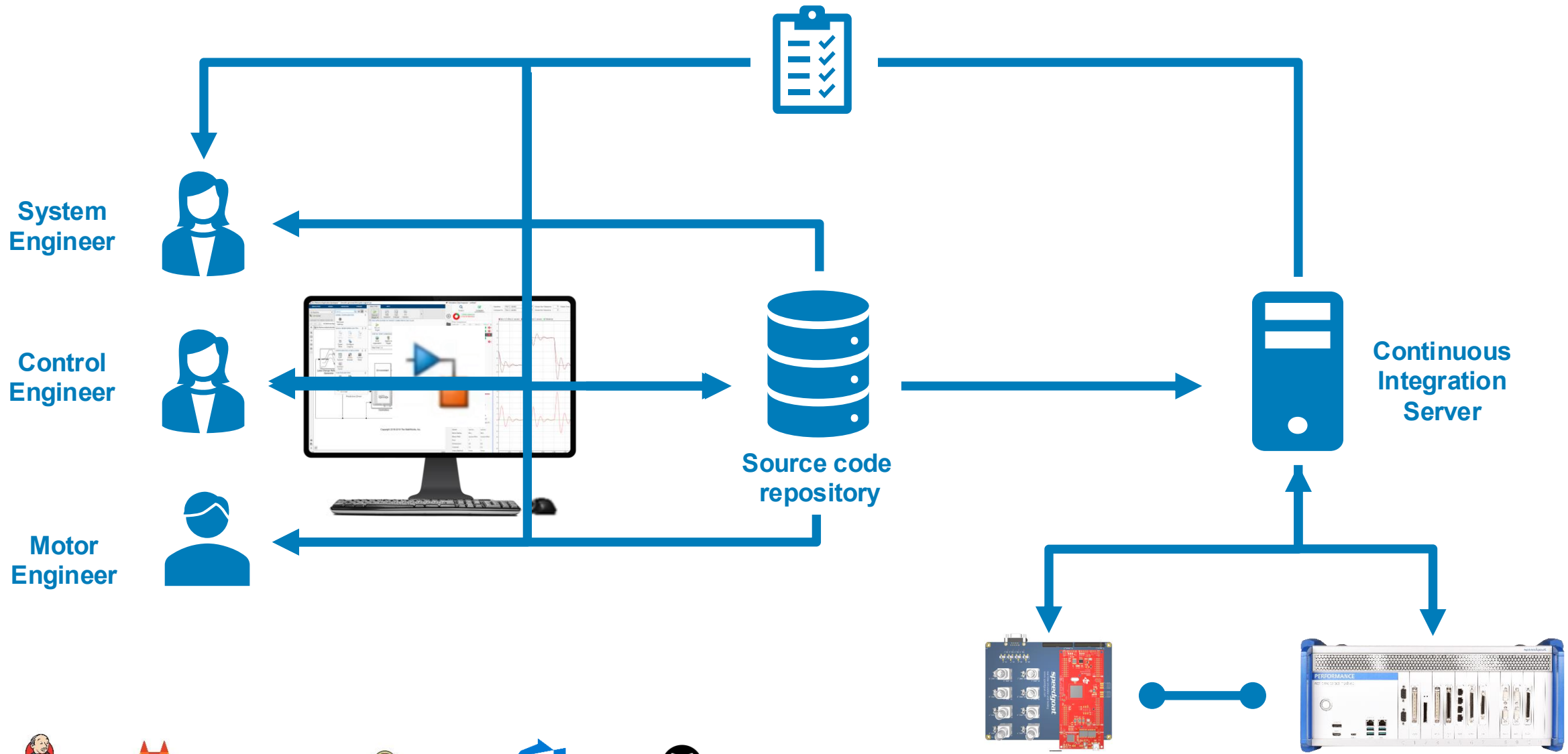

Hardware In the Loop Testing

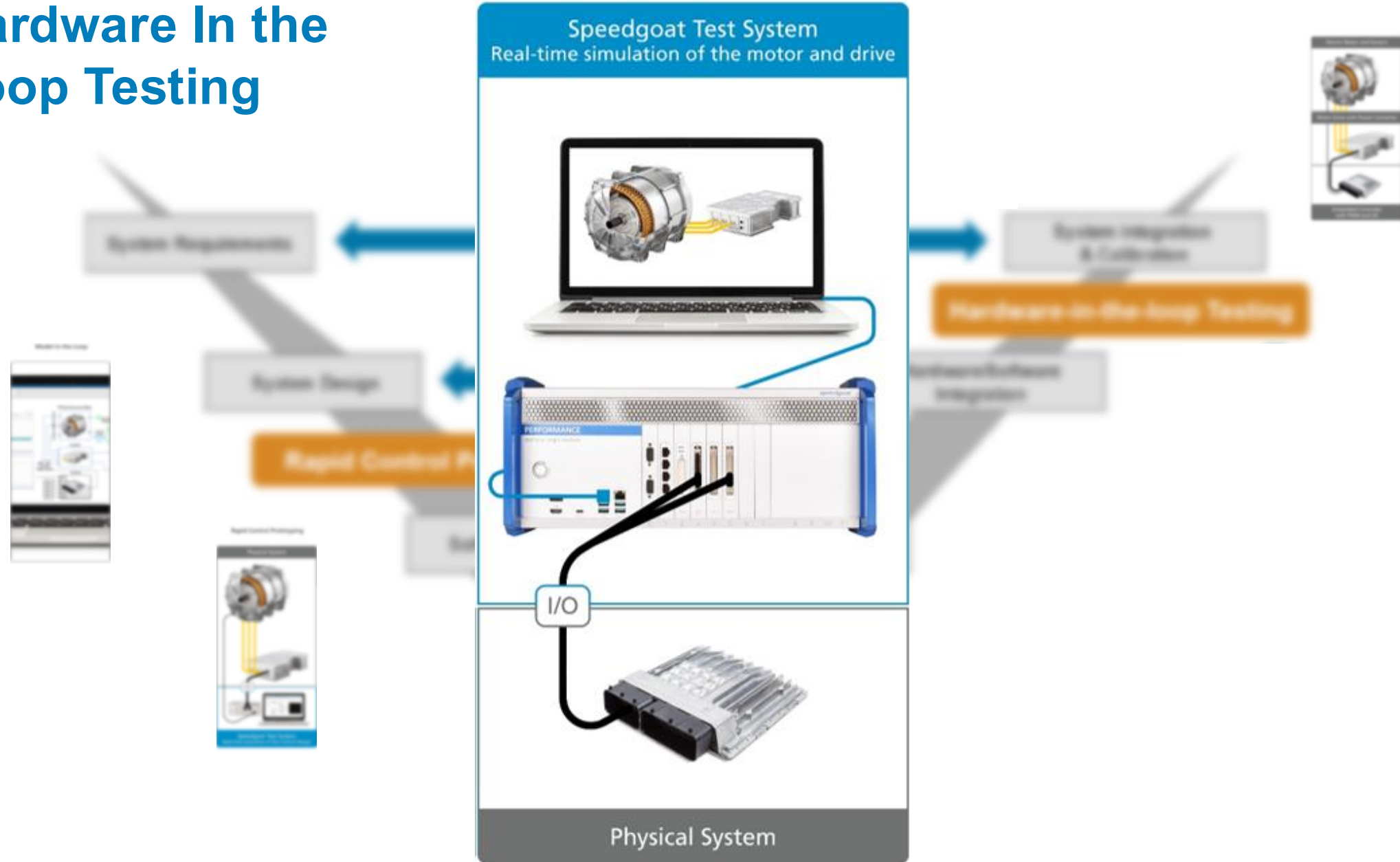

Power HIL

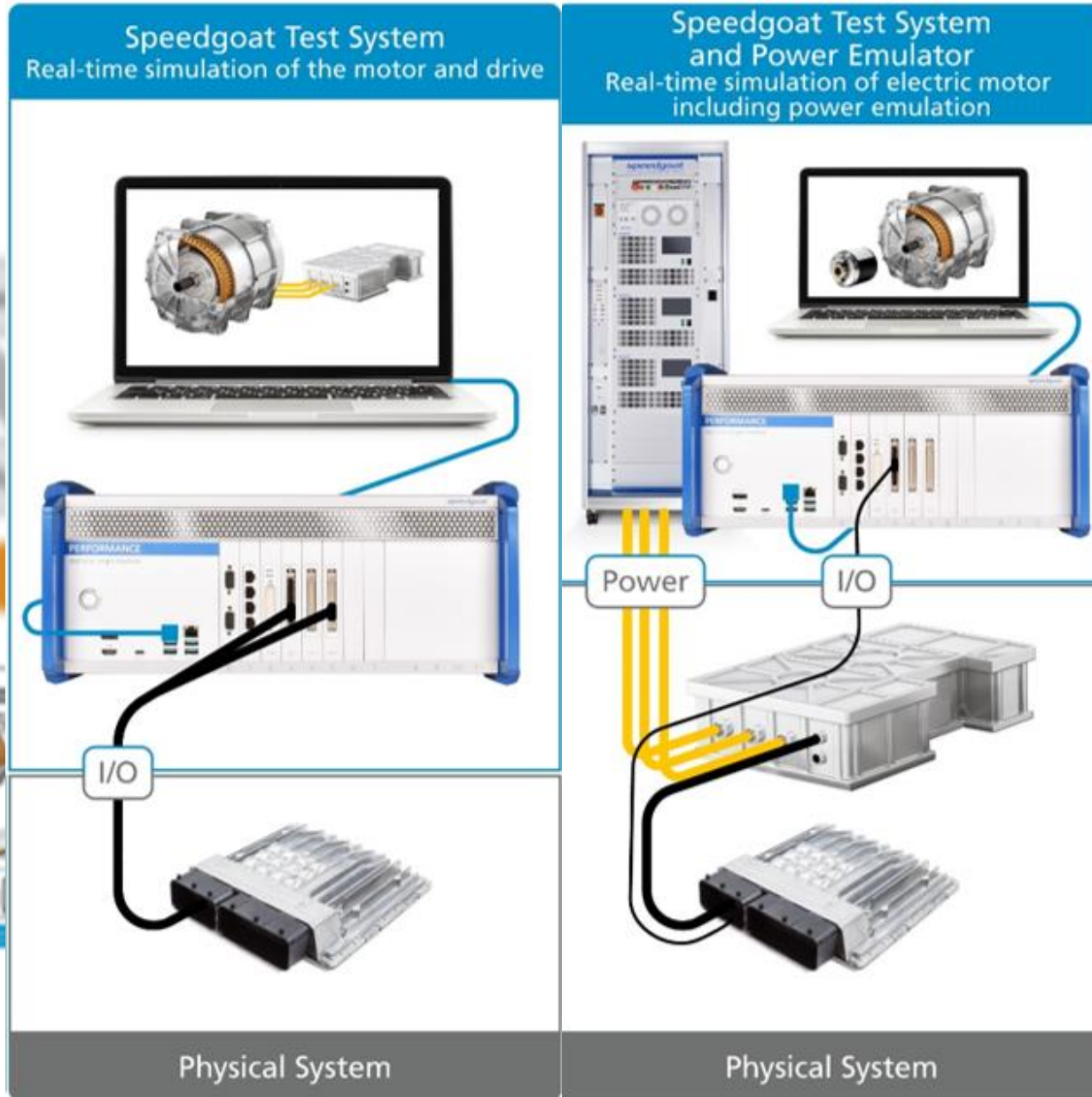

Speedgoat Test System and Power Emulator
Real-time simulation of electric motor including power emulation

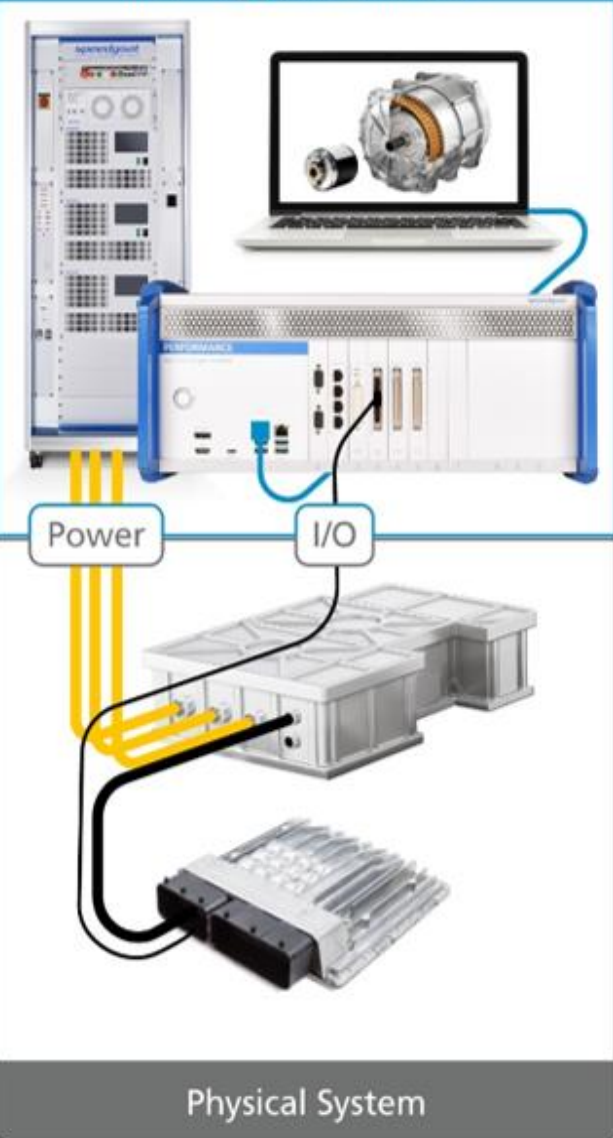

FEM Motor model deployed on the Speedgoat test system

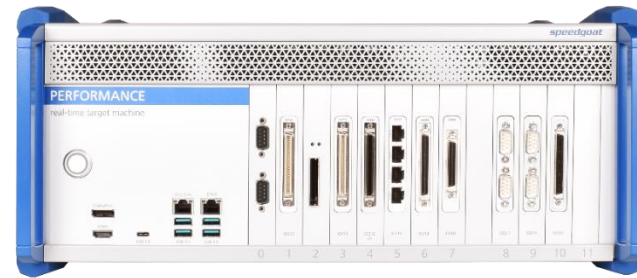

Power device under test: inverter and controller



Speedgoat motor and sensor emulation rack

Development Journey

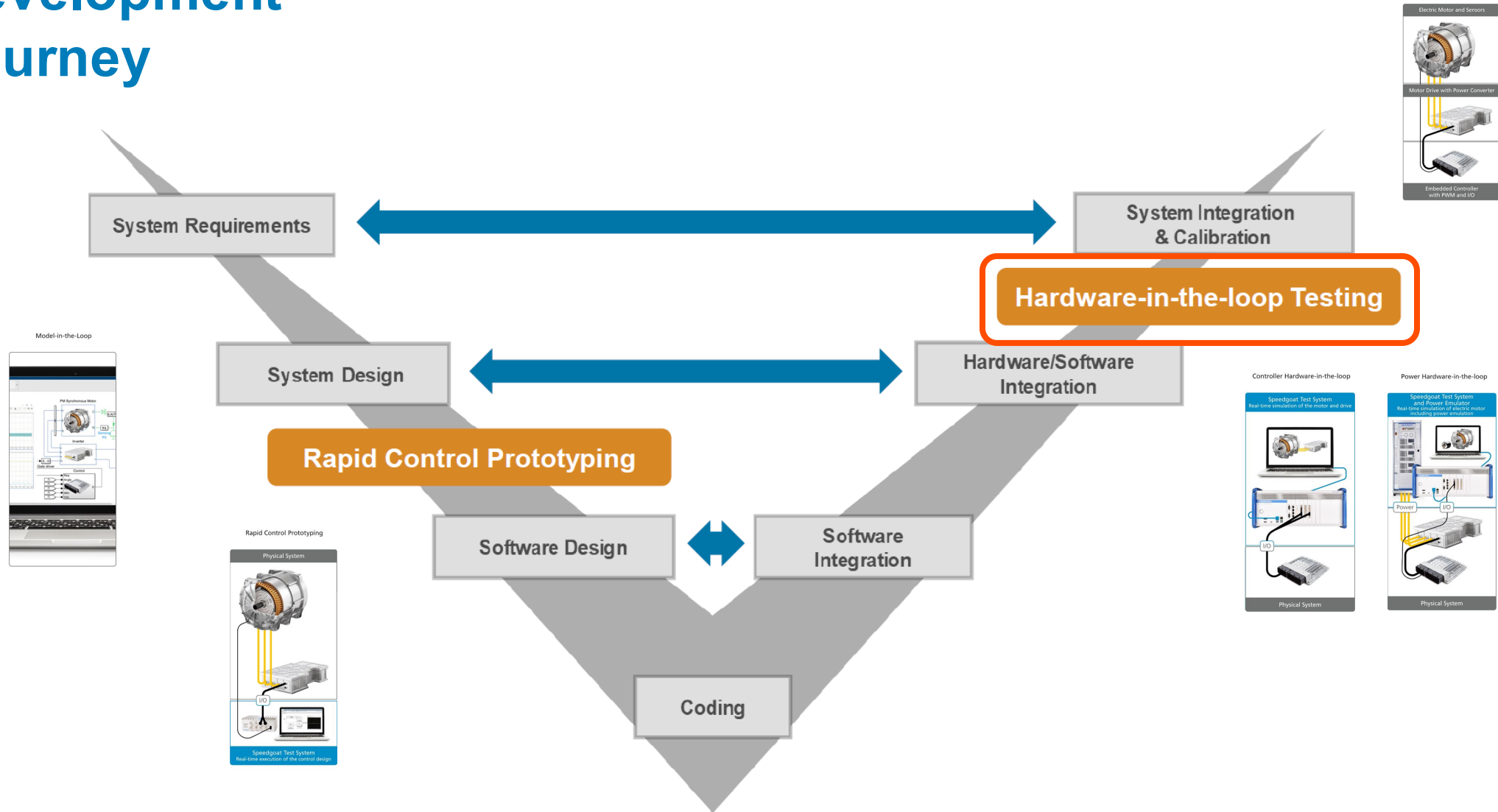

Key Takeaways

- Speedgoat accelerates motor drive developments through real-time testing
 - Rapid control prototyping
 - Controller hardware in the loop
 - Power hardware in the loop
- High fidelity models increase the test coverage for torque ripple challenges
 - Import JMAG-RT[®] models into Speedgoat HIL test systems with new workflows
 - Combine spatial harmonics and switching inverter dynamics on the FPGA to detect high frequency torque ripple components before production
- Speedgoat and Mathworks[®] provide end-to-end development environment

www.speedgoat.com/contact-us



■ MISプロフィール

社名	エムアイエス株式会社 MTT Industrial Systems
設立	2019年4月
本社所在地	東京都新宿区市谷本村町2番5号
資本金	5,000万円
社員数	79名
代表取締役	小林 光幸
執行役員(ソリューション開発)	浅香 勝博
執行役員(品質管理)	矢野 大

■ 事業概要



DSP(デジタル信号処理)事業
研究開発(MBD)ツールから組込(DSP)まで



IPC(産業用コンピュータ)事業
多様なニーズにお応えするコンピュータソリューション



振動事業
国産振動試験コントローラ
ご要求に合わせて振動試験環境を構築

■ Speedgoat代理店業務

■ 納入実績

2016年に国内代理店としてSpeedgoatの取扱い開始 累計400台以上を納入(2025年9月時点)

■ 納入事例

モデルベース開発用途中心にモータ・アクチュエータ制御向けに幅広い業界でご採用

事例：産業用ロボット開発(マニピレータ,ジンバル制御等)、印刷機開発(紙送り,ソート機構)

EV搭向けモータ制御開発、発電機のダクト消音、エレベータ向け回生ブレーキ開発

■ 国内サポート

メーカー機能を持つ代理店として、ご検討時の仕様打合せ～弊社国内工場での出荷検査を実施
弊社専属の技術スタッフとMathworks®社との共同での技術サポートも実施

ご要求に合わせて、専用ハーネス・外部変換基板作成、ラックシステムでの納品もご提案可能



speedgoat
real-time simulation and testing

www.speedgoat.com/contact-us